



## Exhibitor Services Kit

Dear Wisconsin Police Leadership Foundation Winter Conference 2021 Exhibitor:

Valley Expo & Displays is pleased to have been selected as the Official Service Contractor for the upcoming Wisconsin Police Leadership Foundation Winter Conference 2021, being held at Kalahari Resort, February 8-9, 2021. Included in this service kit are forms for ordering various services and equipment for your event. Please read each form carefully and return to the address provided on the order form. Refer to the enclosed General Show Information pages for vital facts and information about this event. If you have any additional questions about Valley Expo & Displays services, please do not hesitate to call or email Valley at the information provided below.

### Valley Ordering Information

Valley Expo & Displays does not take orders over the phone at this time. All preshow orders can be called in, faxed to (815-873-1544), or emailed to ([events@valleyexpodisplays.com](mailto:events@valleyexpodisplays.com)) by **2/3/2021**. After this date orders must be placed at the service desk at the show site during exhibitor move-in. Items ordered at show site are subject to availability.

### Helpful Hints

- Order early and take advantage of the discount pricing to receive discounted rates.
- Ship early to avoid delays. Shipments arriving late at show site will incur an additional cost and delays may occur.
- All correspondence, including final invoices, will be sent to the contact listed on the Recap of Cost & Payment form.
- Valley Expo & Displays will not accept orders without payment in full.

Thank you for your business and we look forward to seeing you at the show!

Please contact our *Exhibitor Services Department* at 877.332.4292; press 1 or email: [events@valleyexpodisplays.com](mailto:events@valleyexpodisplays.com) with any questions you may have.



**VALLEY**

**Register Here** for Online Ordering...  
<http://valleyexpodisplays.com/page/register>  
 EMAIL: [EVENTS@VALLEYEXPODISPLAYS.COM](mailto:EVENTS@VALLEYEXPODISPLAYS.COM)  
 FAX: 815.873.1544

**GENERAL  
SHOW  
INFORMATION****Wisconsin Police Leadership Foundation Winter Conference 2021**

Kalahari Resort, February 8-9, 2021

DISCOUNT PRICE DEADLINE:

1/17/2021

**Valley  
Customer  
Service**

- 815.873.1500 Fax 815.873.1544 email: [events@valleyexpodisplays.com](mailto:events@valleyexpodisplays.com)
- Office Hours: Mon - Fri; 8:00AM - 4:30PM (Central Standard Time)
- No telephone orders accepted; please complete and submit your order by Fax, Email, or Online.

**Show  
Management**

- Floyd "Pete" Peters
- [ppeters@wchiefs.org](mailto:ppeters@wchiefs.org)
- 715-364-2367

**Booth  
Package**

A standard 8'x10' booth will include:

- Burgundy/Silver 8' Back Drape and 3' Side Drape
- (1) 8' skirted table
- (2) Chairs
- (1) 7" x 44" Identification Sign

Your exhibit area is carpeted with facility carpeting.

**Exhibitor  
Schedule**

<b>Exhibitor Move-In:</b>	Sunday	2/7/2021	12:00pm-6:00pm
	Monday	2/8/2021	7:00am-9:00am
<b>Show Hours:</b>	Monday	2/8/2021	9:30am-7:30pm
	Tuesday	2/9/2021	9:00am-3:00pm
<b>Exhibitor Move Out:</b>	Tuesday	2/9/2021	3:00pm-7:00pm

- Drivers for all carriers must be checked in at the Valley Freight Desk for pick-up of freight by: **2/9/2021 on 5:00pm.**

**Shipping  
Addresses****Advance to Warehouse**

Receiving Dates:

**1/14/2021 thru 2/4/2021**

Receiving Hours:

Mon-Fri 7:30AM-2:30PM

TO: Exhibiting Company Name and Booth #

FOR: Wisconsin Police Leadership Foundation Winter Conference 2021

C/O Valley Expo &amp; Displays

YRC Freight

2573 Progress Road

Madison WI 53716

**Direct to Show Site**

Receiving Dates and Times:

**2/7/2021; 12:00pm-6:00pm****2/8/2021; 7:00am-9:00am**

;

TO: Exhibiting Company Name and Booth #

FOR: Wisconsin Police Leadership Foundation Winter Conference 2021

C/O Valley Expo &amp; Displays

Kalahari Resort

1305 Kalahari Drive

Wisconsin Dells WI 53221



**VALLEY**

**Register Here** for Online Ordering...  
<http://valleyexpodisplays.com/page/register>  
 EMAIL: [EVENTS@VALLEYEXPDISPLAYS.COM](mailto:EVENTS@VALLEYEXPDISPLAYS.COM)  
 FAX: 815.873.1544

**GENERAL  
SHOW  
INFORMATION****Wisconsin Police Leadership Foundation Winter Conference 2021**

Kalahari Resort, February 8-9, 2021

DISCOUNT PRICE DEADLINE:  
1/17/2021**Important  
Deadlines**

- Take advantage of order discount pricing! To receive discounted pricing your orders must be received with payment in full no later than the date below. Orders received after discounted price deadline will have their order placed at "Standard" pricing.

**Discount Price Deadline 1/17/2021**

- Freight received before or after receiving dates will incur an additional surcharge.

**Advance Shipments receiving dates :** 1/14/2021 thru 2/4/2021  
**Advance Shipments receiving times :** Mon - Fri 7:30AM-2:30PM  
**Show Site Shipments receiving dates & times:** 2/7/2021; 12:00pm-6:00pm  
 2/8/2021; 7:00am-9:00am  
 ;

**Payment  
Policies**

- Payment information required when placing an order. Orders received without full payment or credit card information will not be processed.
- A credit card on file is required when using Valley Expo & Displays services, any additional charges incurred for equipment and/or services will be billed to the card on file. All charges must be paid prior to close of show.
- For your convenience, we accept all major credit cards as well as cash, checks, ACH, wire transfers. When paying by wire transfer a 3% surcharge will apply.

**Cancellations  
&  
Adjustments**

- Orders cancelled prior to move-in will be charged 50% of the original price. Orders cancelled after move-in begins will be charged 100% of the original price.
- Exhibitor may make adjustments to their order online before the preshow order deadline date.
- No adjustments/refunds will be issued after 14 days from the last day of the event, NO EXCEPTIONS!

**Tax  
Exemption**

- If your company is exempt for payment of sales tax, Valley Expo & Displays requires an exemption certificate for the state in which the services are used. Valley cannot omit sales tax from your order without a copy of your certificate.

**Third Party  
Payment  
Billing  
Exhibitor  
Appointed  
Contractor**

- All third party and EAC forms must be completely filled out and submitted to Valley Expo & Displays. The exhibiting company is ultimately responsible for the payment of all charges. If no arrangements are made for payment of invoice(s) by the third party prior to the last day of the show, charges will revert back to the exhibitor.
- Exhibitor must inform their EAC that they must send a copy of their General Liability Insurance Certificate no later than 30 days prior to the first day of exhibitor move in or they will not be permitted to service your exhibit.

**Miscellaneous**

- Rental items not ordered, yet found in booth space, are invoiced at "Floor" pricing.
- All rental items are subject to applicable taxes.
- All rental items remain the property of Valley Expo & Displays.
- All rental items are subject to availability.
- You are able to place your order without your booth number(s). Booth number(s) may be assigned at a later date and your order will be updated accordingly.
- The show aisles and public space are not a part of exhibitor's booth space and must be kept clear.





**VALLEY**

Register Here for Online Ordering...  
<http://valleyexpodisplays.com/page/register>  
 EMAIL: EVENTS@VALLEYEXPODISPLAYS.COM  
 FAX: 815.873.1544

**THIRD  
PARTY  
BILLING****Wisconsin Police Leadership Foundation Winter Conference 2021**

Kalahari Resort, February 8-9, 2021

This form is to be used if you wish to have a Third Party handle your display, and be billed for services. The Recap of Cost & Payment Form **MUST** be completed by the Third Party to be billed for services, **however, we also must be provided with the Exhibiting Company's credit card information below for our files.** Unless otherwise requested, all charges incurred will be billed to the Third Party.

It should be understood that by signing this form or placing an order the Exhibiting Company agrees it is ultimately responsible for payment of charges. **If your Third Party does not pay all charges in full before the end of the show, all charges will revert to the exhibiting company, due on receipt.**

Exhibiting Company Name: \_\_\_\_\_ Booth #: \_\_\_\_\_

Exhibitor Name: \_\_\_\_\_

Exhibitor Signature: \_\_\_\_\_

Exhibiting Company's credit card information:

\_\_\_ Visa \_\_\_ MC \_\_\_ Amex \_\_\_ Discover \_\_\_ / \_\_\_ Exp. Date \_\_\_ CVC2  
Last 3 digits on back of card, 4 digits on front of AMX

Account #: \_\_\_\_\_

X

Cardholder's Signature \_\_\_\_\_

Print Cardholder's Name \_\_\_\_\_

Cardholder's Billing Address \_\_\_\_\_ City \_\_\_\_\_ State \_\_\_\_\_ Zip \_\_\_\_\_

Exhibiting  
Company  
Information

Indicate which services are to be invoiced to the Third Party:

\_\_\_ ALL VALLEY SERVICES  
 \_\_\_ I&D LABOR/SUPERVISION  
 \_\_\_ MATERIAL HANDLING IN & OUT

\_\_\_ RENTAL FURNITURE/CARPET/SIGNS  
 \_\_\_ BOOTH CLEANING  
 \_\_\_ OTHER: \_\_\_\_\_

Services  
to be  
billed to  
third party

Third Party Company Name: \_\_\_\_\_

Contact Name: \_\_\_\_\_

E-Mail for Invoice: \_\_\_\_\_

Address: \_\_\_\_\_

City: \_\_\_\_\_ State: \_\_\_\_\_ Zip Code: \_\_\_\_\_

Third Party Company's credit card information:

\_\_\_ Visa \_\_\_ MC \_\_\_ Amex \_\_\_ Discover \_\_\_ / \_\_\_ Exp. Date \_\_\_ CVC2  
Last 3 digits on back of card, 4 digits on front of AMX

Account #: \_\_\_\_\_

X

Cardholder's Signature \_\_\_\_\_

Print Cardholder's Name \_\_\_\_\_

Cardholder's Billing Address \_\_\_\_\_ City \_\_\_\_\_ State \_\_\_\_\_ Zip \_\_\_\_\_

Third Party  
Company  
Information



**VALLEY**

Register Here for Online Ordering...  
<http://valleyexpodisplays.com/page/register>  
 EMAIL: [EVENTS@VALLEYEXPDISPLAYS.COM](mailto:EVENTS@VALLEYEXPDISPLAYS.COM)  
 FAX: 815.873.1544

**EXHIBITOR  
APPOINTED  
CONTRACTOR****Wisconsin Police Leadership Foundation Winter Conference 2021**

Kalahari Resort, February 8-9, 2021

Submit this form if the exhibiting company intends to use a contractor other than Valley Expo & Displays. If the exhibiting company fails to comply with any of the requirements listed below the exhibitor appointed contractor will not be permitted to service your exhibit, and Valley Expo & Displays must be hired for installation and dismantle labor. The exhibitor appointed contractor will be able to provide supervision only.

Exhibitor appointed contractors must use labor supplied by Valley Expo & Displays unless the following requirements are fulfilled:

1. The exhibitor must notify Show Management and Valley Expo & Displays of the intention to utilize an independent contractor no later than 30 days prior to the first day of move-in, furnishing the name, address and telephone number of the firm.
2. The Exhibitor shall provide evidence that the Exhibitor Appointed Contractor has proper certificates of insurance with at least the minimum as described below, unless Show Management requires more.
  - a. Comprehensive General Liability not less than \$1,000,000 with respect to injuries to any one person in an occurrence.
  - b. \$2,000,000 with respect to injuries to more than one person in any occurrence.
  - c. Workers' Compensation Insurance including employee liability coverage in the minimum amount not less than \$1,000,000 of individual and/or aggregate coverage and/or statutory limitation.
  - d. Automobile Liability with a limit of not less than \$1,000,000 combined single limit - each accident.
  - e. Umbrella/Excess Liability with a limit of not less than \$1,000,000 each occurrence and {\$1,000,000} each aggregate.
  - f. **Valley Expo & Displays, Show Management and Facility must be named as additional insureds on a primary and non-contributory basis.**
3. The exposition floor, aisles, loading docks, service and storage areas will be under the control of the Official Service Contractor, Valley Expo & Displays.
4. For services such as electrical, plumbing, telephone, and cleaning and drayage, no contractor other than the Official Service Contractor will be approved. This regulation is necessary due to licensing, insurance, and work done on equipment and facilities owned by parties other than the Exhibitor. Exhibitors shall provide only the material and equipment they own and is to be used in their exhibit space.
5. The Exhibitor Appointed Contractor:
  - a. Must agree to abide by all rules and regulations of the show, as outlined in this exhibitor kit, including all union rules and regulations.
  - b. Will share with Valley Expo & Displays all reasonable costs related to its operation, including but not limited to overtime pay for stewards, restoration of exhibit space to its initial condition.
  - c. Must furnish Show Management and Valley Expo & Displays with the names of all on-site employees who will be working on the exposition floor and see that they have and wear at all times necessary identification badges as determined by Show Management.
  - d. Shall be prepared to show evidence that it has a valid authorization from the Exhibitor for services.  
The exhibitor Appointed Contractor may not solicit business on the exhibit floor.
  - e. Must confine its operations to the exhibit area of its clients. No service desks, storage areas, or other work facilities will be located anywhere in the building. The show aisles and public space are not a part of the exhibitor's booth space and must be kept clear.
  - f. Shall provide, if requested, evidence to Valley Expo & Displays that it possesses applicable and current labor contracts and must comply with all labor agreements and practices. The Exhibitor Appointed Contractor must not commit or allow to be committed by persons in its employment any acts could lead to work stoppages, strikes, or labor problems.
  - g. Must coordinate all of its activities with Valley Expo & Displays.
  - h. Must comply with all reasonable rules and regulations of the venue, Show Management and Official Service Contractor in order to create a safe work environment. A failure to do so can result in a delay or termination of your right to continue if the condition cannot be corrected.
6. All information must be received by Valley Expo & Displays' office no later than 30 days prior to the first day of move-in.

**Contractor  
Requirements**

**Exhibiting Company Name:** \_\_\_\_\_

**Booth Number:** \_\_\_\_\_

**Exhibitor Appointed Contractor:** \_\_\_\_\_

**Address:** \_\_\_\_\_

**City:** \_\_\_\_\_ **State:** \_\_\_\_\_ **Zip Code:** \_\_\_\_\_

**Phone Number:** \_\_\_\_\_

**Email Address:** \_\_\_\_\_

**Contact at Show:** \_\_\_\_\_

**Type of Service to be performed:** \_\_\_\_\_

**Contractor  
Information**



**Register Here** for Online Ordering...  
<http://valleyexpodisplays.com/page/register>  
 EMAIL: [EVENTS@VALLEYEXPODISPLAYS.COM](mailto:EVENTS@VALLEYEXPODISPLAYS.COM)  
 FAX: 815.873.1544

**ELECTRICAL  
 SERVICE  
 ORDER FORM**

**Wisconsin Police Leadership Foundation Winter Conference 2021**

Kalahari Resort, February 8-9, 2021

DISCOUNT PRICE DEADLINE:  
 1/17/2021

Orders must be placed by **1/17/2021** to receive discount pricing. Orders received after deadline date will be placed at floor pricing.

All orders subject to availability of power at the show site. Prices include installation to booth, maintenance during the show hours, removal after the show and electrical consumption during show hours. Additional wiring within the booth is not included. Wall and column outlets are not part of the booth space and are not to be used by exhibitors

The following current is generally available: **120 volts, single phase; and 208 volts.** All equipment in use must be properly tagged and wired with complete information as to type of current, voltage, phase cycle, horsepower, etc. Overloading and over current are the exhibitor's responsibility. Prices for electrical service not listed will be quoted upon request.

- Valley is not responsible for any damage to electronic components or equipment.
- No refunds issued for power failure due to reasons beyond our control.

	Description	Quantity	Discount	Standard	Total
120 Volt	500 Watts	_____	\$ 102.00	\$ 132.60	_____
	501 - 1000 Watts	_____	\$ 113.20	\$ 147.20	_____
	1001 - 1500 Watts	_____	\$ 121.75	\$ 158.30	_____
	1501 - 2000 Watts	_____	\$ 131.75	\$ 171.30	_____
	2001 - Over Watts	_____	Call for Quote	Call for Quote	_____

**208 Volt Single Phase AC** | Please contact Kalahari directly for quote.

<b>Extension Cord</b>	10', 3 Prong, 20 AMP Rated	_____	\$ 33.30	\$ 43.30	_____
-----------------------	----------------------------	-------	----------	----------	-------

Special requirements will be quoted on a time and material basis. Electricians hired for special wiring will be charged based on local union rates. If you have special electrical requirements, please be sure to contact us no later than 10 working days prior to the show to ensure availability

<b>Subtotal</b>	\$
<b>6.75% Sales Tax</b>	\$
<b>Total</b>	\$



Exhibiting Company Name: \_\_\_\_\_

Booth Number(s) \_\_\_\_\_

**VALLEY**

Register Here for Online Ordering...  
<http://valleyexpodisplays.com/page/register>  
 EMAIL: EVENTS@VALLEYEXPODISPLAYS.COM  
 FAX: 815.873.1544

**TABLES & CHAIRS  
ORDER FORM****Wisconsin Police Leadership Foundation Winter Conference 2021**

Kalahari Resort, February 8-9, 2021

DISCOUNT PRICE DEADLINE:  
1/17/2021

Orders must be placed by **1/17/2021** to receive discount pricing. Orders received after deadline date will be placed at floor pricing.

All orders subject to availability of equipment. Prices include delivery to booth, set up and removal.  
**Be sure to indicate skirting color . Orders received without color indicated will receive Foreman's choice.**

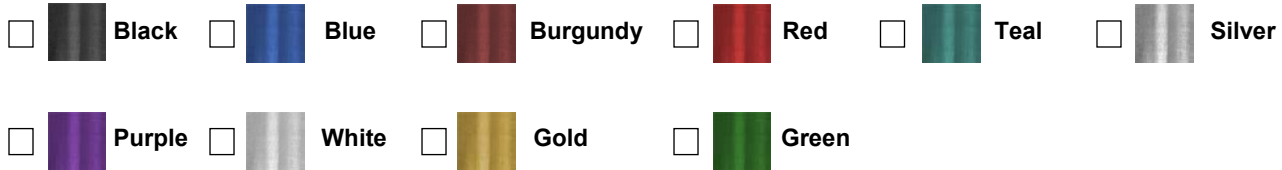
**Skirting Color Selection:**

	Description	Quantity	Discount	Standard	Total
<b>Skirted Tables</b>	4' L x 30" H	_____	\$ 135.35	\$ 176.00	_____
	6' L x 30" H	_____	\$ 160.55	\$ 208.75	_____
	8' L x 30" H	_____	\$ 180.40	\$ 234.55	_____
	4' L x 42" H	_____	\$ 141.90	\$ 184.50	_____
	6' L x 42" H	_____	\$ 175.85	\$ 228.65	_____
	8' L x 42" H	_____	\$ 205.70	\$ 267.45	_____
<b>4th Side Skirting &amp; Drape</b>	30" x 13' Skirting Only (4th Side)	_____	\$ 65.80	\$ 85.55	_____
	42" x 13' Skirting Only (4th Side)	_____	\$ 75.95	\$ 98.75	_____
	3' Drape (Side) per LnFt	_____	\$ 9.90	\$ 12.90	_____
	8' Drape (Back) per LnFt	_____	\$ 13.90	\$ 18.10	_____
<b>Plain Tables</b>	4' L x 30" H	_____	\$ 60.85	\$ 79.75	_____
	6' L x 30" H	_____	\$ 89.40	\$ 116.25	_____
	8' L x 30" H	_____	\$ 106.80	\$ 138.85	_____
	4' L x 42" H	_____	\$ 82.20	\$ 106.90	_____
	6' L x 42" H	_____	\$ 110.35	\$ 143.50	_____
	8' L x 42" H	_____	\$ 127.10	\$ 165.25	_____
	White Vinyl, 8' Long (tabletop covering)	_____	\$ 12.40	\$ 16.15	_____
<b>Cocktail Tables</b>	30" Round, 30" High	_____	\$ 102.60	\$ 133.40	_____
	30" Round, 42" High	_____	\$ 114.65	\$ 149.05	_____
<b>Chairs</b>	Folding Chair	_____	\$ 26.80	\$ 34.85	_____
	Side Chair	_____	\$ 55.20	\$ 71.80	_____
	Padded Chair	_____	\$ 68.60	\$ 89.20	_____
	Bar Stool with Back	_____	\$ 85.40	\$ 111.05	_____

<b>Subtotal</b>	\$ _____
<b>6.75% Sales Tax</b>	\$ _____
<b>Total</b>	\$ _____





**VALLEY**

Register Here for Online Ordering...  
<http://valleyexpodisplays.com/page/register>  
 EMAIL: EVENTS@VALLEYEXPDISPLAYS.COM  
 FAX: 815.873.1544

**ACCESSORIES  
ORDER FORM****Wisconsin Police Leadership Foundation Winter Conference 2021**

Kalahari Resort, February 8-9, 2021

DISCOUNT PRICE DEADLINE:

1/17/2021

Orders must be placed by **1/17/2021** to receive discount pricing. Orders received after deadline date will be placed at floor pricing.

All orders subject to availability of equipment. Prices include delivery to booth and removal. All equipment remains property of Valley Expo & Displays. No orders will be accepted without payment in full.

	Description	Quantity	Discount	Standard	Total
Accessories	Tripod Adjustable Easel	_____	\$ 35.20	\$ 45.80	_____
	Garment Rack	_____	\$ 39.80	\$ 51.75	_____
	Bag Stand	_____	\$ 96.95	\$ 126.05	_____
	Literature Stand	_____	\$ 119.95	\$ 155.95	_____
	Wastebasket	_____	\$ 17.75	\$ 23.10	_____
	8' Upright with Base	_____	\$ 16.70	\$ 21.75	_____
	Crossbar	_____	\$ 11.15	\$ 14.50	_____
	Table Riser 1'x1'x4" White Skirted	_____	\$ 75.25	\$ 97.85	_____
	Posterboard 4' x 8' Horizontal / Vertical (Circle one)	_____	\$ 177.30	\$ 230.50	_____

Labor to assemble Grid Wall is not included. Please refer to the Labor Order Form for assistance in assembling your grid wall if it will be needed.

Grid Wall	2' W x 8' H Panel	_____	\$ 61.15	\$ 79.50	_____
	"T" Base, per set	_____	\$ 28.75	\$ 37.40	_____
	24" Shelf Bracket	_____	\$ 15.75	\$ 20.50	_____
	48" Shelf Bracket	_____	\$ 22.30	\$ 29.00	_____
	6 Ball Waterfall	_____	\$ 10.55	\$ 13.75	_____
	Hang Rail	_____	\$ 11.85	\$ 15.45	_____
	Picture Hanger	_____	\$ 2.85	\$ 3.75	_____
	Hat Display	_____	\$ 6.65	\$ 8.65	_____
	Peg Hook 4", 6", 12" (circle one)	_____	\$ 2.85	\$ 3.75	_____

Exhibiting Company Name: \_\_\_\_\_

Booth Number(s) \_\_\_\_\_

Subtotal	\$	_____
6.75% Sales Tax	\$	_____
<b>Total</b>	<b>\$</b>	<b>_____</b>





**Register Here** for Online Ordering...  
<http://valleyexpodisplays.com/page/register>  
 EMAIL: [EVENTS@VALLEYEXPDISPLAYS.COM](mailto:EVENTS@VALLEYEXPDISPLAYS.COM)  
 FAX: 815.873.1544

**BOOTH CARPET ORDER FORM**

**Wisconsin Police Leadership Foundation Winter Conference 2021**  
 Kalahari Resort, February 8-9, 2021

**DISCOUNT PRICE DEADLINE:**  
 1/17/2021

Orders must be placed by **1/17/2021** to receive discount pricing. Orders received after deadline date will be placed at floor pricing.

Your area is carpeted with facility carpet, any carpet ordered will go on top of existing carpet. Prices include installation, front edge taping and pickup at the close of the show. If your carpet order is different then your booth size you **MUST** include a layout diagram, failure to provide diagram will result in a 25% surcharge and any additional labor onsite to correct placement issues. Please send layout diagram to the information listed above or attach to your order online. Email [events@valleyexpodisplays.com](mailto:events@valleyexpodisplays.com) for instructions on how to attach a file on-line.

*Carpet orders received without color indicated will receive Foreman's choice.*

**Color Selection for Standard Carpeting**

- Blue
  Green
  Black
  Burgundy
  Red
  Gray

If carpet is ordered in multiples of two or more, the carpets are not guaranteed to be a color match and may not cover your entire booth area.

Standard Booth Carpet	Description	Quantity	Advance	Floor	Total
	9' x 10'	_____	\$ 195.30	\$ 253.90	_____
	9' x 20'	_____	\$ 381.50	\$ 495.95	_____
	9' x 30'	_____	\$ 586.35	\$ 762.30	_____

**Color Selection for Custom Carpeting**

- Blue
  Green
  Black
  Burgundy
  Red
  Gray
  Green Jay
  Pepper

Custom size booth carpet is available in 10' widths only. You must include a layout for carpet installation if your carpet request size is different from your booth size. If you require additional carpet to cover steps, skids, or display fixtures, please include a floorplan and a quote will be forwarded to you before we proceed.

Custom Booth Carpet	Carpet Dimension	Square Foot	Advance	Floor	Total
	_____ x _____	_____	\$ 4.70 sq ft	\$ 6.15 sq ft	_____

**Color Selection for Luxury Carpeting**

- Blue
  Green
  Black
  Burgundy
  Red
  Gray

Luxury carpet is available in 10' widths only. Rental also includes plastic covering (Visqueen) for your protection. You must include a layout for carpet installation if your carpet request size is different from your booth size. If you require additional carpet to cover steps, skids, or display fixtures, please include a floorplan and a quote will be forwarded to you before we proceed.

Luxury Booth Carpet	Carpet Dimension	Square Foot	Advance	Floor	Total
	_____ x _____	_____	\$ 6.15 sq ft	\$ 8.00 sq ft	_____

Padding Visqueen Taping	Description	Square Foot	Advance	Floor	Total
	Padding	_____	\$ 2.00 per sq ft	\$ 2.60 per sq ft	_____
	Visqueen (plastic covering)	_____	\$ 1.00 per sq ft	\$ 1.30 per sq ft	_____
	Additional taping	_____	\$ 2.00 per sq ft	\$ 2.60 per sq ft	_____

<b>Subtotal</b>	\$ _____
<b>6.75% Sales Tax</b>	\$ _____
<b>Total</b>	\$ _____



Exhibiting Company Name: \_\_\_\_\_

Booth Number(s) \_\_\_\_\_

**VALLEY**

Register Here for Online Ordering...  
<http://valleyexpodisplays.com/page/register>  
 EMAIL: [EVENTS@VALLEYEXPDISPLAYS.COM](mailto:EVENTS@VALLEYEXPDISPLAYS.COM)  
 FAX: 815.873.1544

SHIPPING  
 ADDRESSES &  
 RECEIVING DATES

## Wisconsin Police Leadership Foundation Winter Conference 2021

Kalahari Resort, February 8-9, 2021

Exhibitors may choose to ship freight to the advance warehouse or directly to show site. Valley Expo & Displays will receive and manage the freight at the warehouse and/or on show site as described in the following pages. Freight handling fees are paid to Valley Expo & Displays for these freight handling services, and are separate from and independent of freight transportation charges, which are paid to a freight carrier such as YRC, ABF, FedEx or any other carrier of the exhibitor's choosing. Exhibitors are responsible for securing a carrier of their choosing and arranging freight transportation to and from the event, and all associated transportation fees.

All inbound shipments must have a bill of Lading and/or certified weight ticket showing the number of pieces, type of merchandise and weight. Shipments received without this information will be delivered to exhibitor's booth without guarantee of piece count or condition. No liability will be assumed by Valley Expo & Displays for such shipments. The weight is rounded up the next one hundred pounds (100 lbs) and is taken from the inbound BOL and/or certified weight ticket. Separate shipments will not be combined. Shipments arriving without a specified weight on the BOL will be assigned and approximate weight by Valley. This weight will prevail.

### SHIPPING ADDRESS AND RECEIVING DATES

#### Advanced Warehouse Shipping Address

EXHIBITING COMPANY NAME  
 BOOTH NUMBER  
**WISCONSIN POLICE LEADERSHIP  
 FOUNDATION WINTER CONFERENCE  
 2021**  
 YRC FREIGHT  
 C/O VALLEY EXPO & DISPLAYS  
 2573 PROGRESS ROAD  
 MADISON WI 53716

- Use this address and information on your inbound bill of lading if shipping your freight to the advance warehouse.
- For your convenience, please use the freight labels provided in this service kit.
- Receiving hours: M - F 7:30AM - 2:30PM.
- All shipments must be prepaid: Collect shipments will be refused.
- Certified weight tickets must accompany all shipments.

#### Advanced Warehouse Receiving Dates

First day freight will be accepted at advanced location: **1/14/2021**

Last day freight will be accepted: **2/4/2021**

#### Direct to Show Site Shipping Address

EXHIBITING COMPANY NAME  
 BOOTH NUMBER  
**WISCONSIN POLICE LEADERSHIP  
 FOUNDATION WINTER CONFERENCE  
 2021**  
 KALAHARI RESORT  
 C/O VALLEY EXPO & DISPLAYS  
 1305 KALAHARI DRIVE

- Use this address and information on your inbound bill of lading if shipping your freight direct to the show site.
- For your convenience, please use the freight labels provided in this service kit.
- All shipments must be prepaid: Collect shipments will be refused.
- Certified weight tickets must accompany all shipments.

#### Direct to Show Site Receiving Dates and Times

#### **Do not send shipments to arrive in advance of 2/7/2021 to the show site.**

**The facility has no means of storage, and will refuse your shipment.**

Days freight will be accepted at show site: **2/7/2021; \*12:00pm-6:00pm**  
**2/8/2021; \*7:00am-9:00am**

; \*

**\*Drivers must check in by an hour before end time**

**Authorization To Provide Freight Handling Services:** By completing the Freight Handling Order Form, it is understood that Valley Expo & Displays and its subcontractors do not automatically insure materials, that insurance, if any, shall be arranged by the Exhibitor and the amounts payable to Valley Expo & Displays for drayage services are based on the value of the material handling services and the scope of Valley Expo & Displays liability as herein set forth. The amounts payable to Valley Expo & Displays are unrelated to the value of the Exhibitor's property being handled by Valley Expo & Displays or its subcontractor. It is impractical and extremely difficult to fix the value of each shipment handled by Valley Expo & Displays or its subcontractors. It is agreed therefore that if Valley Expo & Displays or its subcontractors should be found liable for loss or damage to Exhibitor's materials, the liability shall be limited to the specific article that was physically lost or damaged. Such liability shall be limited to a sum equal to 30 cents per pound per article, with a maximum liability of \$500 per item, or \$1,000 per shipment, whichever amount shall be less, as agreed upon damages but as a penalty, and such agreed upon damages shall be the Exhibitors exclusive remedy. Exhibits left on exhibit floor without return instructions will be returned to our warehouse and held for disposition at an additional charge. Valley Expo & Displays will not be responsible for condition, count or content until such time as exhibits or materials are picked up for removal after the close of the exhibition.



# RUSH

EXHIBITOR MATERIAL

FROM:

## ADVANCE SHIPMENT

TO:

EXHIBITING COMPANY

WISCONSIN POLICE LEADERSHIP FOUNDATION

SHOW NAME

BOOTH NUMBER

C/O VALLEY EXPO & DISPLAYS  
YRC FREIGHT  
2573 PROGRESS ROAD  
MADISON WI 53716

**Shipment Should Arrive Between:**  
*1/14/2021 thru 2/4/2021*

CERTIFIED WEIGHT TICKETS ARE REQUIRED FOR ALL SHIPMENTS. Drivers must check in by 2:30 pm to be guaranteed same day unloading.

Carrier \_\_\_\_\_  
Number of pieces \_\_\_\_\_

# RUSH

EXHIBITOR MATERIAL

FROM:

## ADVANCE SHIPMENT

TO:

EXHIBITING COMPANY

WISCONSIN POLICE LEADERSHIP FOUNDATION

SHOW NAME

BOOTH NUMBER

C/O VALLEY EXPO & DISPLAYS  
YRC FREIGHT  
2573 PROGRESS ROAD  
MADISON WI 53716

**Shipment Should Arrive Between:**  
*1/14/2021 thru 2/4/2021*

CERTIFIED WEIGHT TICKETS ARE REQUIRED FOR ALL SHIPMENTS. Drivers must check in by 2:30 pm to be guaranteed same day unloading.

Carrier \_\_\_\_\_  
Number of pieces \_\_\_\_\_

<h1>RUSH</h1>
EXHIBITOR MATERIAL

FROM:

**DIRECT SHIPMENT**

TO:

\_\_\_\_\_  
*EXHIBITING COMPANY*

**WISCONSIN POLICE LEADERSHIP FOUNDATION**

\_\_\_\_\_  
*SHOW NAME*

\_\_\_\_\_  
*BOOTH NUMBER*

C/O VALLEY EXPO & DISPLAYS  
KALAHARI RESORT  
1305 KALAHARI DRIVE  
WISCONSIN DELLS WI 53221

*Shipment Should Arrive:*  
**2/7/2021; 12:00pm-6:00pm**  
**2/8/2021; 7:00am-9:00am**  
;

CERTIFIED WEIGHT TICKETS ARE REQUIRED FOR ALL SHIPMENTS. .

Carrier \_\_\_\_\_  
Number of pieces \_\_\_\_\_

<h1>RUSH</h1>
EXHIBITOR MATERIAL

FROM:

**DIRECT SHIPMENT**

TO:

\_\_\_\_\_  
*EXHIBITING COMPANY*

**WISCONSIN POLICE LEADERSHIP FOUNDATION**

\_\_\_\_\_  
*SHOW NAME*

\_\_\_\_\_  
*BOOTH NUMBER*

C/O VALLEY EXPO & DISPLAYS  
KALAHARI RESORT  
1305 KALAHARI DRIVE  
WISCONSIN DELLS WI 53221

*Shipment Should Arrive:*  
**2/7/2021; 12:00pm-6:00pm**  
**2/8/2021; 7:00am-9:00am**  
;

CERTIFIED WEIGHT TICKETS ARE REQUIRED FOR ALL SHIPMENTS

Carrier \_\_\_\_\_  
Number of pieces \_\_\_\_\_



# Exhibit Services

Reliable trade show shipping services





### The show must go on!

YRC Freight is ready to customize transportation solutions for any exhibit shipment, any size load, delivering great service, savings and simplicity.

After the show, specify YRC Freight for the move out on the materials handling agreement (MHA), then give us a call. We'll take it from there.

And if others handle your trade show shipping, remember to tell them about YRC Freight savings and service.

## Delivering confidence at the show

- 100% inbound service guarantee\* at no additional cost
- On-site Exhibit managers monitor your inbound shipments for on-time, smooth move ins
- Time-Critical expedited
- Comprehensive North American coverage and online visibility

## Giving you more for your money

- Lowest trade show shipping fees in the industry
- 30 days free storage prior to the show; a great way to save when moving from show to show
- No detention fees at trade shows
- No extra fees for weekend/after-hour pickups

## Keeping it simple for you

- Exhibit customer service representatives available 24/7; call 1-800-531-EXPO (3976)
- Around-the-clock assistance with quotes, bookings, tracking or expediting
- Single-shipment transportation for your entire display
- Online shipment visibility throughout the move on [my.yrcfreight.com](http://my.yrcfreight.com)

\* Subject to applicable Tariffs and Rules and Conditions publications.

**Confidence Delivered:**

[yrcfreight.com](http://yrcfreight.com) | 800.531.EXPO (3976) |  Live Chat





Register Here for Online Ordering...  
<http://valleyexpodisplays.com/page/register>  
 EMAIL: EVENTS@VALLEYEXPDISPLAYS.COM  
 FAX: 815.873.1544

## ADVANCE SHIPMENT FREIGHT HANDLING ORDER FORM

### Wisconsin Police Leadership Foundation Winter Conference 2021

Kalahari Resort, February 8-9, 2021

As the official service contractor, Valley Expo & Displays is the exclusive provider of freight services. Material handling includes unloading your exhibit material, storing up to 30 days in advance at the warehouse address, delivering it to the booth, handling of empty containers to and from storage, and removing of material from the booth for loading onto your outbound carrier. Shipments by carriers not giving delivery receipts or bill of lading, will be accepted and delivered to your booth space with no guarantee of piece count or condition. No liability whatsoever will attach to Valley Expo & Displays for those shipments. Valley Expo & Displays assumes no liability for lost or damaged items stored during any event. Cost to transport your exhibit material to and from the convention or event is not included.

#### Information

- Freight is accepted **1/14/2021** thru **2/4/2021**.
- To ensure timely arrival of your materials at show site, freight should arrive by **2/4/2021**. Freight will still be received after the deadline date; however, delays may occur and additional charges will apply.
- The warehouse receives shipments Monday through Friday, except holidays.
- The warehouse will accept crates, cartons, skids, trunks/cases and carpets.
- All shipments must have a bill of lading or delivery slip indicating the number of pieces, type of merchandise and weight.
- Certified weight tickets must accompany all shipments.

#### Advantages

There are several advantages to shipping in advance to the warehouse versus directly to the show site:

- Exhibitors can confirm shipment has arrived in advance of the move-in date.
- Materials will be delivered to your booth prior to your arrival on site. Exceptions may occur.
- Delivery dates and times are more flexible.

#### Estimating Material Handling Charges

- Charges will be based on the weight of your shipment. Each shipment received is considered separately. The shipment weight will be rounded to the next 100 lbs. Each 100 lbs. is considered one "cwt" (one hundred weight). All shipments are subject to reweigh. (200lbs minimum charged on all shipments weighing 51lbs - 200lbs)
- Select the category that best describes your shipment. There are two categories of freight:
  - Crated:** Material that is skidded or is in any type of shipping container that can be unloaded at the dock with no additional handling required.
  - Special Handling:** Material delivered by a carrier in such a manner that it requires additional handling, such as ground unloading, stacked or constricted space unloading, designated piece unloading, shipment integrity, alternate delivery location, loads mixed with pad wrapped material, carpet and/or pad only shipments, no documentation and shipments that require additional time, equipment or labor to unload. **Federal Express, UPS Ground, & DHL** are included in this category due to their delivery procedures.
- Add Overtime and/or Double Time surcharges for inbound if material is delivered to the booth during the overtime and/or double time period.
- Add Overtime and/or Double Time surcharges for outbound if material is loaded onto the outbound carrier during the overtime and/or double time period.
- Add the early/late surcharge if the shipment is accepted at the advance warehouse before or after the deadline dates listed above.

**Straight Time :** 8:00 AM to 4:30 PM Monday through Friday  
**Overtime:** 4:30 PM to 8:00 AM Monday through Friday; All day Saturday  
**Double Time:** All day Sunday and Holidays  
 (Overtime/Double Time will be applied to all freight received at the warehouse that must be moved into or out of booth during above listed times)

	Rate Classifications	Price Per CWT	200lb Minimum
<b>Rates</b>	Crated or Skidded	\$ 96.40	\$ 192.80
	Special Handling	\$ 125.15	\$ 250.30

#### Small Package

A small package shipment is a shipment totaling any number of pieces with a combined weight not to exceed 50lbs that is received on the same day from the same shipper and delivered by the same carrier

First Carton	\$ 65.85
Each Additional Carton	\$ 15.95

#### Additional Surcharges

Early/Late Delivery Show Site/Advance Warehouse Surcharge	20% Surcharge per CWT
Overtime - Inbound and/or Outbound Surcharge	25% Surcharge per CWT
Double Time - Inbound and/or Outbound Surcharge	50% Surcharge per CWT
No Weight ticket - Reweigh Surcharge	25% Surcharge per CWT

**\*\*This show moves in and/or out on Overtime and/or Double Time and is subject to Additional Surcharges for shipments**

#### Estimate of Charges

Rate Classification	Weight	CWT	Price Per CWT	Estimated
	÷ 100 =		\$	\$
<b>Additional Surcharges (% added to price per CWT)</b>				
Inbound	Out Bound		N/A	
_____ OT (+ 25%) _____ DT (+ 50%)	_____ OT (+ 25%) _____ DT (+ 50%)			
<b>Small Package</b>				
First Carton				\$
Additional Carton	_____ # of additional carton x \$15.95			\$
This calculation is only an estimate. Invoicing will be done from the actual weight. Adjustments will be made accordingly.				<b>Total Estimated</b> \$





Register Here for Online Ordering...  
<http://valleyexpodisplays.com/page/register>  
 EMAIL: EVENTS@VALLEYEXPDISPLAYS.COM  
 FAX: 815.873.1544

**DIRECT SHIPMENT  
 FREIGHT HANDLING  
 ORDER FORM**

## Wisconsin Police Leadership Foundation Winter Conference 2021

Kalahari Resort, February 8-9, 2021

As the official service contractor, Valley Expo & Displays is the exclusive provider of freight services. Material handling includes unloading your exhibit material, delivering it to the booth, handling of empty containers to and from storage, and removing of material from the booth for loading onto your outbound carrier. Shipments by carriers not giving delivery receipts or bill of lading, will be accepted and delivered to your booth space with no guarantee of piece count or condition. No liability whatsoever will attach to Valley Expo & Displays for those shipments. Valley Expo & Displays assumes no liability for lost or damaged items stored during any event. Cost to transport your exhibit material to and from the convention or event is not included.

### Information

- Freight will be accepted: **2/7/2021; 12:00pm-6:00pm & 2/8/2021; 7:00am-9:00am & ; .**
- Do not ship to the facility prior to **2/7/2021**. Early shipments to the show site may be refused.
- All shipments must have a bill of lading or delivery slip indicating the number of pieces, type of merchandise and weight.
- Certified weight tickets must accompany all shipments.
- Ship pre-paid; collect shipments will be refused.
- Freight Questionnaire must be submitted with this form.

### Estimating Material Handling Charges

- Charges will be based on the weight of your shipment. Each shipment received is considered separately. The shipment weight will be rounded to the next 100 lbs. Each 100 lbs. is considered one "cwt" (one hundred weight). All shipments are subject to reweigh. (200lbs minimum charged on all shipments weighing 51lbs - 200lbs)
- Select the category that best describes your shipment. There are three categories of freight:
  - Crated:** Material that is skidded or is in any type of shipping container that can be unloaded at the dock with no additional handling required.
  - Special Handling:** Material delivered by a carrier in such a manner that it requires additional handling, such as ground unloading, stacked or constricted space unloading, designated piece unloading, shipment integrity, alternate delivery location, loads mixed with pad wrapped material, carpet and/or pad only shipments, no documentation and shipments that require additional time, equipment or labor to unload. **Federal Express, UPS Ground, & DHL** are included in this category due to their delivery procedures.
  - Uncrated:** material that is shipped loose or pad-wrapped, and/or unskidded machinery without proper lifting bars or hooks.
- Add overtime and/or double time charges for inbound if material is delivered to the booth during the overtime and/or double time period.
- Add overtime and/or double time charges for outbound if material is loaded onto the outbound carrier during the overtime and/or double time period.
- Add the early/late surcharge if the shipment is accepted at the show site before or after the deadline dates listed above.

**Straight Time :** 8:00 AM to 4:30 PM Monday through Friday  
**Overtime:** 4:30 PM to 8:00 AM Monday through Friday; All day Saturday  
**Double Time:** All day Sunday and Holidays  
 (Overtime/Double Time will be applied to all freight received at the show site that must be moved into or out of booth during above listed times)

Rates	Rate Classifications	Price Per CWT	200lb Minimum
	Crated or Skidded	\$ 91.40	\$ 182.80
	Special Handling	\$ 118.70	\$ 237.40
	Uncrated	\$ 141.90	\$ 283.80

### Small Package

A small package shipment is a shipment totaling any number of pieces with a combined weight not to exceed 50lbs that is received on the same day from the same shipper and delivered by the same carrier

First Carton	\$ 65.85
Each Additional Carton	\$ 15.95

### Additional Surcharges

Early/Late Delivery Show Site/Advance Warehouse Surcharge	20% Surcharge per CWT
Overtime - Inbound and/or Outbound Surcharge	25% Surcharge per CWT
Double Time - Inbound and/or Outbound Surcharge	50% Surcharge per CWT
No Weight ticket - Reweigh Surcharge	25% Surcharge per CWT

**\*\*This show moves in and/or out on Overtime and/or Double Time and is subject to Additional Surcharges for shipments**

### Estimate of Charges

Rate Classification	Weight	CWT	Price Per CWT	Estimated
	÷ 100 =		\$	\$
<b>Additional Surcharges (% added to price per CWT)</b>				
Inbound	Out Bound		N/A	
_____ OT (+ 25%) _____ DT (+ 50%)	_____ OT (+ 25%) _____ DT (+ 50%)			
<b>Small Package</b>				
First Carton				\$
Additional Carton	_____ # of additional carton x \$15.95			\$
<b>Total Estimated</b>				\$

This calculation is only an estimate. Invoicing will be done from the actual weight. Adjustments will be made accordingly.



Register Here for Online Ordering...
http://valleyexpodisplays.com/page/register
EMAIL: EVENTS@VALLEYEXPODISPLAYS.COM
FAX: 815.873.1544

FREIGHT SERVICE QUESTIONNAIRE

Wisconsin Police Leadership Foundation Winter Conference 2021
Kalahari Resort, February 8-9, 2021

ALL EXHIBITORS SHIPPING FREIGHT MUST RETURN THIS FORM

1. Estimate total number of pieces being shipped:

- Crated
Uncrated
Machinery
Total

2. Indicate total number of trucks in each category that you will use:

- Van Line
Common Carrier
Flatbed
Company Truck
Overseas Container

3. List carrier name(s):

Blank lines for listing carrier names

4. If using a Customs Broker, please print name:

Blank line for customs broker name

Phone

5. Print the name of person in charge of your move-in:

Blank line for person name

Phone

6. What is the minimum number of days required to set your displays?

Blank line for days

7. What is the weight of the single heaviest piece that must be lifted?

Lbs.

8. What is the total weight of your exhibit or equipment being shipped?

Lbs.

9. Is there any special handling equipment required to unload your exhibit materials, i.e. extended forklift blades, special slings, lifting bars, etc.?

Blank lines for special handling equipment

It is the responsibility of the Exhibitor to provide proper special handling instructions. Failure to provide these instructions will result in the elimination of any liability for loss or damage by Valley Expo & Displays.

DIRECT SHIPMENTS ONLY:

1. What date and time are you scheduling your shipment(s) to arrive on-site?

Blank lines for date and time

Exhibiting Company Name:

Booth Number(s)





Register Here for Online Ordering...  
<http://valleyexpodisplays.com/page/register>  
 EMAIL: EVENTS@VALLEYEXPDISPLAYS.COM  
 FAX: 815.873.1544

## OUTBOUND SHIPPING INFORMATION

### Wisconsin Police Leadership Foundation Winter Conference 2021

Kalahari Resort, February 8-9, 2021

Outbound shipping is not an automatic process. Each shipment must have freight handling services on order and a completed Bill of Lading in order to ship materials from the show. All pieces must be labeled individually. After materials are packed, labeled and ready to be shipped, the completed Bill of Lading must be turned in at the Valley Service Desk. **Do not leave this in your booth with your shipment.** Call your designated carrier with pick-up information. In the event your carrier fails to show by carrier check in time indicated on the shipping information form, your shipment will be rerouted to Valley Expo & Displays' official show carrier at exhibitor's expense.

#### Tear Down

The show closes at **3:00pm-7:00pm on 2/9/2021**. Please do not tear down prior to the close of the show. Empty crates will be brought to your booth after Aisle carpet is removed.

#### Outbound Pick-Up Address & Carrier Check In

- All outbound shipments must be picked up at the show site location.
- Each exhibitor is responsible for arranging prompt pick-up and removal of outbound shipments. If you are using a carrier other than the official show carrier, it is your responsibly to contact the carrier and advise them that they must be checked in and the appropriate times.
- Drivers are placed in line for loading on a first-come, first serve basis, provided the exhibitor is completely packed and a Bill of Lading has been turned into the Service Desk. Should your carrier fail to check in by the designated time, Valley Expo & Displays reserves the right to re-route the shipment via the official show carrier as necessary, at the exhibitor's expense.

#### Carrier check in Date and Time: 5:00pm; 2/9/2021

#### Outbound Bill of Lading

- All outbound shipments require a Valley Bill of Lading. Bills of Lading will be distributed to your booth before move out. If you do not receive a bill of lading please see the Valley Service Desk.
- A Bill of Lading must be completed for each truckload and destination. If you have multiple shipping destinations or multiple truckloads to one destination, additional Bill of Ladings are available at the valley Service Desk.
- No Bill of Lading will be issued until your invoice has been paid in full.
- Return the completed Bill of Lading to the Valley Service Desk when your materials are packaged and ready to be shipped. Turning in your Bill of Lading indicates to Valley that your shipment is ready to be loaded.
- The name of the carrier listed on your completed Bill of Lading must match the name of the carrier checking in or your freight will not be released.

#### Outbound Miscellaneous Services

Shrink Wrap	\$ 80.35 per pallet + dismantle labor (please see labor order form for dismantle labor rates)
Banding	\$ 1.35 per foot + dismantle labor (please see labor order form for dismantle labor rates)

#### Labels

Each individual item in your shipment must be clearly labeled. Blank labels are available at the Valley Service Desk.





**Register Here** for Online Ordering...  
<http://valleyexpodisplays.com/page/register>  
 EMAIL: [EVENTS@VALLEYEXPDISPLAYS.COM](mailto:EVENTS@VALLEYEXPDISPLAYS.COM)  
 FAX: 815.873.1544

# OUTBOUND BILL OF LADING INSTRUCTION

## BILL OF LADING INSTRUCTIONS

These instructions are designed to clarify information required on a Bill of Lading.  
**COMPLETE ALL THE BLUE SHADED AREAS - PRESS HARD**

The Show Name Today's Date

The booth number you are exhibiting under. This is where Valley physically looks for your shipment, therefore, the correct booth number is critical.

Circle the total number of bills of lading that will be completed for your booth space. Separate bills must be completed for different destinations and for different methods of shipping. (ie YRC, FedEx, van line, etc.)

The company name you are exhibiting under. The name of this convention center or exhibit hall, including city and state.

List the name of the carrier you have chosen to ship your freight.

If you have selected a carrier other than our house carrier, you must initial here. This informs Valley what to do with your freight in the event your carrier does not check in by the designated time.

What does your shipment consist of? Fill in the exact quantities of each "kind of package" be very specific include weights.

Name and address of the party responsible for the freight charges.

Check "Collect" if the "Ship To" address and the "Freight charges guaranteed by" addresses are the same. If the addresses are different, then you have involved a third party and the "Prepaid/3rd Party" option should be selected.

Received in perfect good condition, except as noted

By receiving this bill of lading Valley Expo & Displays assumes no responsibility for shipments left in booth by exhibitor. All materials are subject to their own control and correction at time of shipment from booth. Valley reserves the right to remove any material from booth at any time. Exhibitor agrees to comply with the rules and regulations of Valley Expo & Displays. This is to certify that the named articles are properly crated, packed, marked and sealed, and are in proper condition for transportation according to the applicable regulations of the Department of Transportation.

Shipper (Signature) Shipper (Print)

This Bill of Lading is to be signed by the shipper and agent of carrier.

VALLEY COPY

**STRAIGHT BILL OF LADING No. 112141**

INSTRUCTIONS - Complete all of the shaded areas and return to the service desk when all materials are ready for shipment. For further instructions on proper use of this form, see back side.

No. of separate shipments in booth: 1 2 3 4

SHIP FROM: Show Name Booth Number Exhibit Facility Exhibitor Name Address City State Zip Carrier

SHIP TO: Show Name Booth Number Exhibit Facility Exhibitor Name Address City State Zip Special Instructions

In the event a selected carrier fails to show on the first move out day, Valley will force shipment accordingly via house carrier \_\_\_\_\_, Inc.

RECEIVED, subject to the classifications and tariffs in effect on the date of the issue of this Bill of Lading, the property described below, in apparent good order, except as noted (contents and condition of contents of package unknown), marked consigned, and delivered as indicated above, which said carrier (the word carrier being understood throughout this contract as meaning any person or corporation in possession of the property under the contract) agrees to carry to the usual place of delivery at said destination, if or to any other place, arranged by another carrier on the route to said destination. It is mutually agreed, as to each carrier of all or any portion of said property over \$5 or any portion of said route to destination, and as to each party of any time interest in all or any of said property, that every service to be performed hereunder shall be subject to all the terms and conditions of the Uniform Domestic Straight Bill of Lading set forth (1) in Uniform Freight Classification in effect on the date hereof, if this is a rail or rail-water shipment, or (2) in the motor carrier classification or tariff if this is a motor carrier shipment.

Shipper hereby certifies that he is familiar with all the terms and conditions of the said bill of lading, including those on the back thereof, set forth in the classification or tariff which governs the transportation of this shipment, and the said terms and conditions are hereby agreed to by the shipper and accepted for himself and his assignee.

Pieces	Description of Articles	Weight	Class	Subject to section 7 of Limits of Liability, if the shipment is to be delivered to the consignee without recourse on the consignee, the consignee shall sign the following statement:
	Crates (Wooden) Exhibit Materials			The carrier shall not make delivery of this shipment without payment of freight and all other lawful charges.
	Cartons (Cardboard)			
	Fiber cases/Trunks			
	Skids/Pallets			
	Carpet (Color _____)			
	Machines			
Total				

Signature of Consignor

**FREIGHT CHARGES**

Prepaid/3rd party Collect

By receiving this bill of lading Valley Expo & Displays assumes no responsibility for shipments left in booth by exhibitor. All materials are subject to their own control and correction at time of shipment from booth. Valley reserves the right to remove any material from booth at any time. Exhibitor agrees to comply with the rules and regulations of Valley Expo & Displays. This is to certify that the named articles are properly crated, packed, marked and sealed, and are in proper condition for transportation according to the applicable regulations of the Department of Transportation.

Received in perfect good condition, except as noted

Date \_\_\_\_\_ Time \_\_\_\_\_

Checker Signature \_\_\_\_\_

Driver (Signature) \_\_\_\_\_

Driver (Print) \_\_\_\_\_

Place Pro label Here

SHIPPER FREIGHT CHARGES TO: Company Name Address City State Zip

**RETURN TO THE VALLEY SERVICE DESK AFTER YOUR MATERIALS ARE PACKED AND READY TO BE SHIPPED. DO NOT TURN THE BILL OF LADING IN EARLY.**

**A SHIPPING LABEL MUST BE PLACED ON EACH PIECE.**

**LEAVE YOUR PACKED SHIPMENT IN YOUR BOOTH.**





## RENTAL EXHIBITS

# RENTAL EXHIBITS THAT INSPIRE

Time, cost savings and flexibility are key benefits to renting a tradeshow exhibit. Renting an exhibit is a cost-effective alternative and provides the opportunity to “try before you buy” so you can evaluate what works best for your event and exhibiting needs. Renting saves precious marketing dollars and allows you the flexibility to change your display for each audience and for each show. One of the greatest benefits of renting a tradeshow booth is the time you will save!

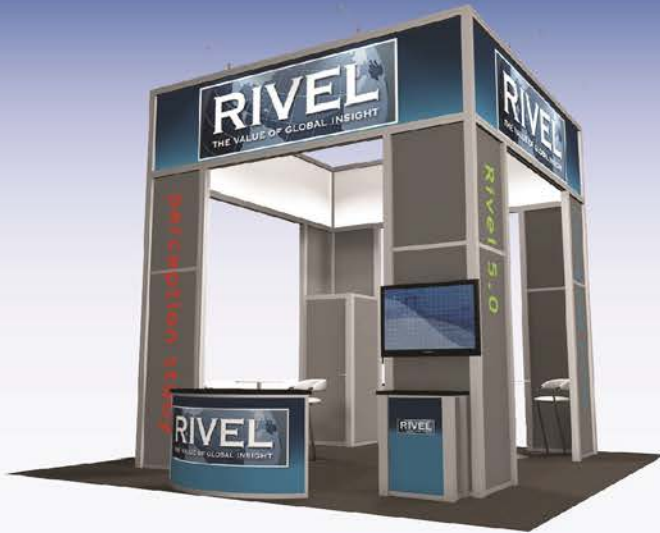

**VALLEY**

Register Here for Online Ordering...  
<http://valleyexpodisplays.com/page/register>  
 EMAIL: [EVENTS@VALLEYEXPODISPLAYS.COM](mailto:EVENTS@VALLEYEXPODISPLAYS.COM)  
 FAX: 815.873.1544

**MISCELLANEOUS**

## Wisconsin Police Leadership Foundation Winter Conference 2021

Kalahari Resort, February 8-9, 2021

### Counter Kit 129 Fan Counter



- Freestanding counter constructed of aluminum extrusion gray base panels and black laminate top with locking storage.
- Overall dimensions approximately: 64.75"wide x 33.407"deep x 40" high.

Rentals include: front graphic panel, material handling, installation and dismantle of exhibit only.

Not included: Graphic taxes and outbound shipping of your purchased

### Counter Kit 135 Rectangle Counter



- Freestanding counter constructed of aluminum extrusion gray base panels and black laminate top and locking storage.
- Dimensions: 48"wide x 24" deep x 40"high.

Rentals include: front graphic panel, material handling, installation and dismantle of exhibit only.

Not included: Graphic taxes and outbound shipping of your purchased

### Counter Kit 137 Rectangle Counter with Display Case Top



- Freestanding counter constructed of aluminum extrusion gray base panels and a clear plex top section and locking storage.
- Dimensions: 38.25"wide x 18.875"deep x 40"high.

Rentals include: front graphic panel, material handling, installation and dismantle of exhibit only.

Not included: Graphic taxes and outbound shipping of your purchased graphic from the event.



**VALLEY**

**Register Here** for Online Ordering...  
<http://valleyexpodisplays.com/page/register>  
 EMAIL: [EVENTS@VALLEYEXPODISPLAYS.COM](mailto:EVENTS@VALLEYEXPODISPLAYS.COM)  
 FAX: 815.873.1544

## Wisconsin Police Leadership Foundation Winter Conference 2021

Kalahari Resort, February 8-9, 2021

DISCOUNT PRICE DEADLINE:  
1/17/2021

### Counter Kit 40 Square



- Freestanding counter constructed of aluminum extrusion gray base panels and black laminate top and locking storage.
- Dimensions: 40"high x 39.75"wide x 30"deep.

Rentals include: front graphic panel, material handling, installation and dismantle of exhibit only.

Not included: Graphic taxes and outbound shipping of your purchased graphic from the event.

### Counter Kit MOD-1573



- Backlit Direct Print Graphic with Standoffs.
- Locking Door.
- White Laminate Finish.
- Dimensions: 40" wide x 40" high x 20" deep.

Rentals include: graphic, material handling, installation and dismantle of exhibit only.

NOT included: electrical service and electrical labor to install lights. Graphic taxes and outbound shipping of your purchased graphic from the event.

### Counter Kit MOD-1540 Backlit



- Custom Counter with Backlighting. (Plex Graphic)
- Locking Door and Shelf.
- Dimensions: 60" wide x 24" deep x 44" high.

Rentals include: graphic, material handling, installation and dismantle of exhibit only.

NOT included: electrical service and electrical labor to install lights. Graphic taxes and outbound shipping of your purchased graphic from the event.



**VALLEY**

Register Here for Online Ordering...  
<http://valleyexpodisplays.com/page/register>  
 EMAIL: EVENTS@VALLEYEXPDISPLAYS.COM  
 FAX: 815.873.1544

MISCELLANEOUS

## Wisconsin Police Leadership Foundation Winter Conference 2021

Kalahari Resort, February 8-9, 2021

### Counter Kit 138 Full View Display Case



- Freestanding case has plex top, front, sides with two interior plexi shelves, lights and locks.
- Dimensions: 72"wide x 24"deep x 40"high.

Rentals include: material handling, installation and dismantle of exhibit only.

### Counter Kit 95 Long Rectangle



- Freestanding counter constructed of aluminum extrusion gray base panels and black laminate top with locking storage.
- Dimensions are 40" high x 96" wide x 30" deep.

Rentals include: front graphic panel, material handling, installation and dismantle of exhibit only.

Not included: Graphic taxes and outbound shipping of your purchased graphic from the event.





**VALLEY**

**Register Here** for Online Ordering...  
<http://valleyexpodisplays.com/page/register>  
 EMAIL: [EVENTS@VALLEYEXPODISPLAYS.COM](mailto:EVENTS@VALLEYEXPODISPLAYS.COM)  
 FAX: 815.873.1544

**MISCELLANEOUS**

## Wisconsin Police Leadership Foundation Winter Conference 2021

Kalahari Resort, February 8-9, 2021

### Charging Table



- White laminated table with 3 USB hubs.
- Dimensions: 72" long by 36" wide and 42" high.

Rentals include: material handling, installation and dismantle of exhibit only.

NOT included: electrical service and electrical labor to install lights.

### Kit 0303 3' BeMatrix Lightbox



- Freestanding lightbox constructed of aluminum extrusion with a gray base and side panels. The lightbox can be used as both single sided and double sided.
- Graphics are produced on a backlit fabric and sewn with SEG to insert into the frame of the box.
- Dimensions are 39" wide x 96" high x 8" deep (20" with base at the bottom).

Rentals include: graphic, material handling, installation and dismantle of exhibit only.

NOT included: electrical service and electrical labor to install lights. Graphic taxes and outbound shipping of your purchased graphic from the event.



**VALLEY**

Register Here for Online Ordering...  
<http://valleyexpodisplays.com/page/register>  
 EMAIL: EVENTS@VALLEYEXPODISPLAYS.COM  
 FAX: 815.873.1544

**10FT DISPLAYS**

## Wisconsin Police Leadership Foundation Winter Conference 2021

Kalahari Resort, February 8-9, 2021

### Inline Kit 1102



- Aluminum extrusion frame with cool gray sintra infill panels.
- Dimensions: 10ft wide x 8ft high.

Rentals include: standard carpeting, visqueen, padding, graphic, material handling, installation and dismantle of exhibit only.

NOT Included: Graphic taxes and outbound shipping of your purchased graphic from the event.

### Kit SYK-1024



- Lightweight Engineered Aluminum SEG Frames.
- Press-Fit SEG Fabric Graphic.
- (1) Backwall Workstation Counter with (2) Wireless/Wired Charging Ports.
- (1) Large Monitor Mount Monitor Size Guidelines: Up to 43" Monitor.
- (1) Locking Reception Counter with Vinyl Graphic.
- (1) Detachable Floating Graphic with Graphic Brackets.
- (1) iPad Swivel Mount.
- (2) Locking Aluminum Base Plates.

Rentals include: standard carpeting, visqueen, padding, graphic, material handling, installation and dismantle of exhibit only.

NOT Included: Electronic/audio visual equipment, electrical service and electrical labor to install lights. Graphic taxes and outbound shipping of your purchased graphic from the event.

*Please call Valley for available audio visual equipment*



**VALLEY**

Register Here for Online Ordering...  
<http://valleyexpodisplays.com/page/register>  
 EMAIL: [EVENTS@VALLEYEXPODISPLAYS.COM](mailto:EVENTS@VALLEYEXPODISPLAYS.COM)  
 FAX: 815.873.1544

**10FT DISPLAYS**

## Wisconsin Police Leadership Foundation Winter Conference 2021

Kalahari Resort, February 8-9, 2021

### Kit RE-1055



- Engineered Aluminum Structure.
- Large Format Silicone Edge Fabric Graphic.
- 7.5 ft. x 7.5 ft Aluminum Extrusion Frame.
- (2) Convex Two-Piece Wings. — Sintra
- (2) 5 Watt LED Light.
- (1) Monitor Support and Monitor Mount.
- Dimensions 116" wide x 18" deep x 90" high

Rentals include: standard carpeting, visqueen, padding, graphic, material handling, installation and dismantle of exhibit only.

NOT Included: Electronic/audio visual equipment, electrical service and electrical labor to install lights. Graphic taxes and outbound shipping of your purchased graphic from the event.

*Please call Valley for available audio visual equipment*

### Kit RE-1018



- Lightweight Recycled Aluminum Extrusion Frame.
- (6) ECO-Glass Stand Off Accents.
- (1) Tension Fabric Graphic-Velcro Attachment. (66" W x 86" H)
- (1) ECO-Board Direct Print Stand Off Graphic Header.
- (2) LED Energy Efficient Lights.
- (1) Small Monitor Mount. (10" to 36")
- Dimensions (1) 54" long x 28" wide x 11" high.

Rentals include: standard carpeting, visqueen, padding, graphic, material handling, installation and dismantle of exhibit only.

NOT Included: Electronic/audio visual equipment, electrical service and electrical labor to install lights. Graphic taxes and outbound shipping of your purchased graphic from the event.

*Please call Valley for available audio visual equipment*



**VALLEY**

Register Here for Online Ordering...  
<http://valleyexpodisplays.com/page/register>  
 EMAIL: [EVENTS@VALLEYEXPODISPLAYS.COM](mailto:EVENTS@VALLEYEXPODISPLAYS.COM)  
 FAX: 815.873.1544

**10FT DISPLAYS**

## Wisconsin Police Leadership Foundation Winter Conference 2021

Kalahari Resort, February 8-9, 2021

### Kit 1058



- Freestanding hardwall constructed of aluminum extrusion with a gray base and side panels.
- Graphics are produced on Sintra and applied to frame with velcro.
- Dimensions: 117"wide x 96"high x 4"deep (20" with base at the bottom).
- (1) Counter Kit 135.

Rentals include: standard carpeting, visqueen, padding, graphic, material handling, installation and dismantle of exhibit only.  
 NOT Included: Electronic/audio visual equipment, electrical service and electrical labor to install lights. Graphic taxes and outbound shipping of your purchased graphic from the event.

*Please call Valley for available audio visual equipment*

### Kit 1023



- Freestanding lightbox backwall constructed of aluminum extrusion with a gray base and side panels. The lightbox is used as a single sided backwall unit.
- Graphics are produced on a backlit fabric and sewn with SEG to insert into the frame of the box.
- Dimensions: 117"wide x 96"high x 8"deep (20" with base at the bottom).
- (1) Counter Kit 135.

Rentals include: standard carpeting, visqueen, padding, graphic, material handling, installation and dismantle of exhibit only.  
 NOT included: electrical service and electrical labor to install lights. Graphic taxes and outbound shipping of your purchased graphic from the event.



**VALLEY**

Register Here for Online Ordering...  
<http://valleyexpodisplays.com/page/register>  
 EMAIL: [EVENTS@VALLEYEXPODISPLAYS.COM](mailto:EVENTS@VALLEYEXPODISPLAYS.COM)  
 FAX: 815.873.1544

**20FT DISPLAYS**

## Wisconsin Police Leadership Foundation Winter Conference 2021

Kalahari Resort, February 8-9, 2021

### Kit 2367

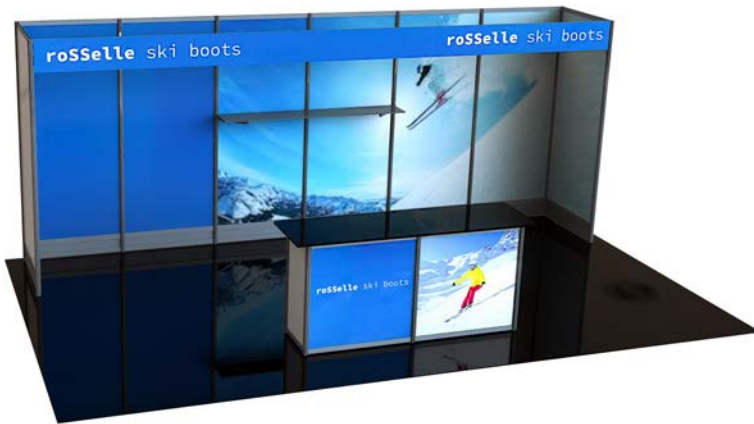

- Aluminum extrusion frame with cool gray sintra infill panels.
- 2 meter back wall counter with sliding doors.
- (2) 2 meter shelves.
- Dimensions: 20' wide x 8' high.

Rentals include: standard carpeting, visqueen, padding, graphic, material handling, installation and dismantle of exhibit only.

NOT included: electrical service and electrical labor to install lights. Graphic taxes and outbound shipping of your purchased graphic from the event.

### Kit RE-2056



- Engineered Aluminum Structure
- (2) Large Format Silicone Edge Fabric Graphics. (SEG)
- (2) 7.5 ft. x 7.5 ft Aluminum Extrusion Frames.
- (4) 5 Watt LED Lights.
- Dimensions 180" wide x 18" deep x 90" high.

Rentals include: standard carpeting, visqueen, padding, graphic, material handling, installation and dismantle of exhibit only.

NOT included: electrical service and electrical labor to install lights. Graphic taxes and outbound shipping of your purchased graphic from the event.



**VALLEY**

Register Here for Online Ordering...  
<http://valleyexpodisplays.com/page/register>  
 EMAIL: EVENTS@VALLEYEXPODISPLAYS.COM  
 FAX: 815.873.1544

**20FT DISPLAYS**

## Wisconsin Police Leadership Foundation Winter Conference 2021

Kalahari Resort, February 8-9, 2021

### Kit 2395



- Straight aluminum frame.
- Zipper pillowcase fabric graphic.
- Dimensions: 235" wide x 92.49" high x 17.72" deep.

Rentals include: standard carpeting, visqueen, padding, graphic, material handling, installation and dismantle of exhibit only. Graphic taxes and outbound shipping of your purchased graphic from the event.

### Kit 2389



- Freestanding hardwall constructed of aluminum extrusion with a gray base and side panels.
- Graphics are produced on Sintra and applied to frame with velcro.
- Dimensions: 234" wide x 96" high x 4" deep (20" with base at the bottom).
- (1) Counter Kit 135

Rentals include: standard carpeting, visqueen, padding, graphic, material handling, installation and dismantle of exhibit only.

NOT Included: Electronic/audio visual equipment, electrical service and electrical labor to install lights. Graphic taxes and outbound shipping of your purchased graphic from the event.

*Please call Valley for available audio visual equipment*



**VALLEY**

Register Here for Online Ordering...  
<http://valleyexpodisplays.com/page/register>  
 EMAIL: [EVENTS@VALLEYEXPODISPLAYS.COM](mailto:EVENTS@VALLEYEXPODISPLAYS.COM)  
 FAX: 815.873.1544

**20FT DISPLAYS**

## Wisconsin Police Leadership Foundation Winter Conference 2021

Kalahari Resort, February 8-9, 2021

### Kit RE-2053



- Engineered Aluminum Extrusion.
- SuperNova™ LED Technology.
- Silver Anodized Finish.
- Dimensions 233" wide x 95" high x 28" deep.
- (1) Front Silicone Edge Fabric Graphic. (approx. 95" H x 42" W)
- (1) Front Silicone Edge Fabric Graphic. (approx. 95" H x 68" W)
- (1) Front Silicone Edge Fabric Graphic. (approx. 95" H x 110" W)
- (3) Rear Reflective Fabrics.
- (2) Backlit Counters with Locking Storage.

Rentals include: standard carpeting, visqueen, padding, graphic, material handling, installation and dismantle of exhibit only.

NOT included: electrical service and electrical labor to install lights. Graphic taxes and outbound shipping of your purchased graphic from the event.

### Kit RE-2028



- Engineered Aluminum Extrusion with Silicone Edge Graphics.
- (2) Flat Canopies with Black Fabric Covers.
- (6) 50 Watt Halogen Arm Lights.
- (2) Small Curved Counters with open storage.
- Front Counter Infill Graphic Dimensions: 31-15/16" wide x 34-7/8" high.
- SEG Fabric Graphic Dimensions: 239.341" wide x 84" high.

Rentals include: standard carpeting, visqueen, padding, graphic, material handling, installation and dismantle of exhibit only.

NOT included: electrical service and electrical labor to install lights. Graphic taxes and outbound shipping of your purchased graphic from the event.



**VALLEY**

Register Here for Online Ordering...  
<http://valleyexpodisplays.com/page/register>  
 EMAIL: EVENTS@VALLEYEXPODISPLAYS.COM  
 FAX: 815.873.1544

20 x 20 ISLAND  
 DISPLAYS

## Wisconsin Police Leadership Foundation Winter Conference 2021

Kalahari Resort, February 8-9, 2021

### Kit 4087



Brushed aluminum extrusion creating a center tower and two side panels with gray infill panels.

- (6) Stem Lights
- (1) Counter Kit 129
- Dimensions 20ft x 20ft x 12ft x or 16ft High

Rentals include: standard carpeting, visqueen, padding, graphic and material handling.  
 NOT included: Labor to install or dismantle exhibit. electrical service and electrical labor to install lights. Graphic taxes and outbound shipping of your purchased graphic from the event.

### Kit RE-9049



- Lightweight Recycled Aluminum Extrusion Frame
- (6) LED Energy Efficient Lights
- (4) Literature Shelves
- (1) Large Monitor Mount
- (1) Built-in Tower Counter w/ Black Laminated Top
- (2) Frosted Acrylic Divider Panels
- (1) Large Curved Counter with Locking Door for Storage (White Sintra Infill Panels)
- Dimensions (1) 103" x 55" x 37" @ 900 lbs.

Rentals include: standard carpeting, visqueen, padding, graphic and material handling,  
 NOT Included: Labor to install or dismantle exhibit. Electronic/audio visual equipment, electrical service and electrical labor to install lights. Graphic taxes and outbound shipping of your purchased graphic from the event.

*Please call Valley for available audio visual equipment*





**VALLEY**

Register Here for Online Ordering...  
<http://valleyexpodisplays.com/page/register>  
 EMAIL: [EVENTS@VALLEYEXPODISPLAYS.COM](mailto:EVENTS@VALLEYEXPODISPLAYS.COM)  
 FAX: 815.873.1544

20 x 20 ISLAND  
 DISPLAYS

## Wisconsin Police Leadership Foundation Winter Conference 2021

Kalahari Resort, February 8-9, 2021

### Kit RE-9024

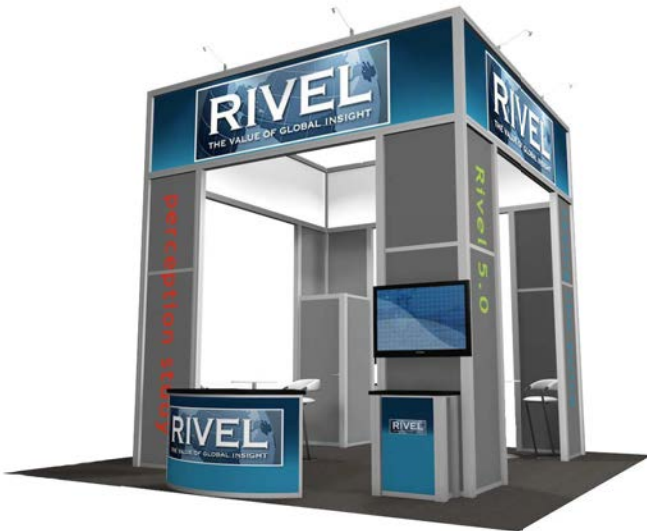

- 16' High Extrusion Structure.
- (1) Large Curved Counter with Locking Door & Interior Shelf.
- (2) Small Rectangular Counters with Interior Shelves.
- (1) Storage Closet with Locking Door.
- (2) Large Monitor Mounts. (up to 46")
- (8) Halogen Arm Lights.
- (3) Bar Stools with backs.

Rentals include: standard carpeting, visqueen, padding, graphic and material handling.

NOT Included: Labor to install or dismantle exhibit. Electronic/ audio visual equipment, electrical service and electrical labor to install lights. Graphic taxes and outbound shipping of your purchased graphic from the event.

*Please call Valley for available audio visual equipment*

### Kit RE-9020



- Double Deck with Stairs and Railings.
- 16 ft. x 18 ft. Overall Footprint.
- Perfect for 20 X 20 and Larger Spaces.
- 10 ft. x 16 ft Upper Deck Floor Space.
- Bolted Connections for Structural Beams. (greater stability)
- Up to 500 kg/M2 Upper Deck Load.
- Wood Deck Flooring.

Rentals include: material handling

Not included: installation and dismantle of exhibit





**Register Here** for Online Ordering...  
<http://valleyexpodisplays.com/page/register>  
 EMAIL: [EVENTS@VALLEYEXPDISPLAYS.COM](mailto:EVENTS@VALLEYEXPDISPLAYS.COM)  
 FAX: 815.873.1544

**Wisconsin Police Leadership Foundation Winter Conference 2021**

Kalahari Resort, February 8-9, 2021

Orders must be placed by **1/17/2021** to receive discount pricing. Orders received after deadline date will be placed at floor pricing.

All orders subject to availability of equipment. All display rentals include graphic. All 10Ft, 20Ft and 20 x 20 Displays include standard carpeting, visqueen, padding, and material handling. Electrical service and labor to install lights are not included. Graphic taxes and outbound shipping of your purchased graphic from the event are not included. 20' x 20 Displays do not included labor to install or dismantle, please refer to the labor order form in this kit for cost and to order.

	<b>Kit#</b>	<b>Description</b>	<b>Rental Price</b>
Counters	129	Fan Counter	\$ 1,524.20
	135	Rectangle Counter	\$ 965.25
	137	Rectangle Counter w/Display	\$ 1,062.40
	040	Square Counter	\$ 1,262.00
	1573	Backlit Counter	\$ 1,575.25
	1540	Backlit Counter w/Accent	\$ 1,504.30
	138	Full View Display Counter	\$ 1,047.80
	095	Long Rectangle Counter	\$ 1,962.00
Miscellaneous	CT01	Charging Table	\$ 1,112.00
	0303	3' BeMatrix Lightbox	\$ 1,812.00
10FT Displays	1102	Inline Floor Standing Hardwall	\$ 2,533.15
	1024*	10' Fabric Graphic Backwall	\$ 4,010.60
	1055*	10" Fabric Graphic Backwall w/Accents Wings	\$ 2,673.80
	1018*	Fabric Graphc Backwall w/ECO-Glass Stand Off Accents	\$ 2,736.80
	1058	BeMatrix Backwall	\$ 3,692.00
	1023	BeMatrix LightBox wall	\$ 5,243.00
20FT Displays	2367	Inline 20 Ft Hardwall w/Counter	\$ 6,158.40
	2056*	20' Fabric Graphic Backwall	\$ 4,192.00
	2395	Formuate Master 20ft WV1 Vertical Straight Fabric Backwall	\$ 2,798.75
	2389	20' Fabric Backwall w/Counter	\$ 7,024.00
	2053	Inline Lightbox Graphic Backwall w/Counters	\$ 7,381.10
	2028*	20' Fabric Backwall w/Canopies	\$ 7,044.20
20' x 20' Displays	4087*	Island 20 x 20 Ft Display	\$ 15,478.70
	9049*	Island 20 x 20 Display w/Connecting Accents	\$ 12,139.50
	9024*	Island 20 x 20 Display w/Header Graphics	\$ 21,809.50
	9020	Deck Island	Call For Quote

**Color Selection for Standard Carpeting (10Ft, 20Ft, and 20' x20' Displays ONLY)**

- Blue
  Green
  Black
  Burgundy
  Red
  Gray

<b>Kit #</b>	<b>Qty</b>	<b>Price</b>
		\$

\*Kit that include lighting, Electrical service and labor to install lights are not included.

<b>Subtotal</b>	\$
<b>6.75% Sales Tax</b>	\$
<b>Total</b>	\$



Exhibiting Company Name: \_\_\_\_\_

Booth Number(s) \_\_\_\_\_



**Register Here** for Online Ordering...  
<http://valleyexpodisplays.com/page/register>  
 EMAIL: [EVENTS@VALLEYEXPODISPLAYS.COM](mailto:EVENTS@VALLEYEXPODISPLAYS.COM)  
 FAX: 815.873.1544

**AUDIO VISUAL  
ORDER FORM**

**Wisconsin Police Leadership Foundation Winter Conference 2021**

Kalahari Resort, February 8-9, 2021

All Audio Visual rental includes; deliver and setup of equipment, HDMI cord, TV remote, power strip and pickup of equipment at close of show. Orders must be placed by

**Item Description**

**Event Rental**

**LED Displays**

75" Led Display	\$1,800.00
65" Led Display	\$1,350.00
55" Led Display	\$1,000.00
49" Led Display	\$ 775.00
40" Led Display	\$ 600.00
32" Led Display	\$ 425.00
24" Led Display	\$ 275.00

**Display Accessories**

Dual Pole Floor Stand with Shelf	\$ 175.00
----------------------------------	-----------

**Multi Media Solutions**

Blu Ray Player	\$ 125.00
Media Player	\$ 125.00

**Please indicate:**     Table Top Stand     Wall Mount     Floor Stand

**Please call for quote if you are looking for other AV offerings.**

**Delivery:** An authorized representative must be present at the time of delivery and pickup. Equipment will be delivered to and picked up from your booth. Delivery fee may apply.

**Labor, Installation & Dismantle (I&D):** Any order requiring labor, including the installation and dismantling of equipment, will be subject to a labor charge please refer to labor install and dismantle order forms located within this kit for labor rates. Valley Expo & Displays does not supply labor to mount hanging brackets to your booth. This must be done prior to setting up any equipment that is to be mounted on your booth.

**Equipment:** Customer is responsible for the security of rented equipment and will be required to pay for any items that are lost or stolen during the rental period (anytime after delivery and before pickup of equipment).

**Guarantee:** Equipment is guaranteed to be operational upon delivery to your booth. It is assumed that the renter has an understanding of the operation of equipment. Equipment problems must be reported immediately to our service desk. Any loss or damage of said equipment will be paid for by the renter. **Cancellation:** Equipment rental cancellation will be charged 50% of rental fee. On-site cancellations will be charged 100% of rental fee.

**Payment:** All exhibit orders must be reserved with a major credit card with payment in full due at the time the order is placed.

Please write down description below of item ordering below:

Item Description	QTY

<b>Subtotal</b>	\$
<b>6.75% Sales Tax</b>	\$
<b>Total</b>	\$



Exhibiting Company Name: \_\_\_\_\_

Booth Number(s) \_\_\_\_\_



**Register Here** for Online Ordering...  
<http://valleyexpodisplays.com/page/register>  
 EMAIL: [EVENTS@VALLEYEXPDISPLAYS.COM](mailto:EVENTS@VALLEYEXPDISPLAYS.COM)  
 FAX: 815.873.1544

**EVENT LABOR  
 EXHIBITOR SUPERVISED  
 ORDER FORM**

**Wisconsin Police Leadership Foundation Winter Conference 2021**

Kalahari Resort, February 8-9, 2021

**DISCOUNT PRICE DEADLINE:**  
 1/17/2021

Orders must be placed by **1/17/2021** to receive discount pricing. Orders received after deadline date will be placed at floor pricing.

All installation and dismantling work will be performed under the direction of exhibitor supervising qualified personnel in compliance with any applicable labor contracts. If you wish to hire Valley Expo & Displays to supervise work performed, please complete the Valley Supervised Labor form.

**Rate Information**

Description	Discount	Standard
<b>Straight Time</b> - 8:00 AM and 4:30 PM on weekdays	\$ 110.90	\$ 144.20
<b>Overtime</b> - Before 8:00 AM and after 4:30 PM on weekdays and all day Saturday	\$ 166.35	\$ 216.30
<b>Double time</b> - All day Sunday and holidays	\$ 221.80	\$ 288.40

**A minimum charge** of one (1) hour per man will apply to all labor orders, with the time commencing upon assignment of labor in accordance with your order. Half (1/2) hour minimum per man is charged thereafter.

Labor must be cancelled in writing 24 hours in advance to avoid a one (1) hour cancellation fee per worker.

We will attempt whenever possible to perform the work on straight time, contingent upon the schedules of the show producer and/or convention facility.

**Labor check in & Out**

Exhibitor must check in at the Valley Service Desk to pick up laborers. Upon completion of work, exhibitors must return to the Valley Service Desk to release laborers and to sign the work order indicating the labor completed. Failure to pick up labor at the Valley Service Desk will result in a one (1) hour per man no show charge.

**Hours of Operation**

When scheduling dismantle, be sure to allow sufficient time for empty containers to be returned to your booth

<u>Move In Dates &amp; Times</u>	<u>Move Out Dates &amp; Times</u>
2/7/2021; 12:00pm-6:00pm	2/9/2021; 3:00pm-7:00pm
2/8/2021; 7:00am-9:00am	;
;	;

**Requesting Times**

Time can only be guaranteed at the start of the working day (8:00AM), or the official beginning of set up, if later in the day. We will make every attempt to provide labor at times subsequent to 8:00 AM (or start of official set up); however, such starting times are approximate as they are dependent up on completion times of prior job assignments.

Requesting Date & Time	Date Labor Requested	Time Labor Requested
Installation		AM or PM
Dismantle		AM or PM
Requested starting times cannot be guaranteed, however, every effort is made to meet all request		

**Description of labor requested**

**MUST** provide brief description of labor requested (e.g. lay carpet, install pop-up)

**Estimate of Charges**

Computation of Labor Charges	# of Workers X	# Hours X	Labor Rate	Total Estimate
Installation			\$	\$
Dismantling			\$	\$

**Authorization to Provide Labor Services:** By completing the Event Labor Form, it is understood that Valley Expo & Displays and its subcontractors do not automatically insure materials, that insurance, if any, shall be arranged by the Exhibitor and the amounts payable to Valley Expo & Displays for labor services are based on the value of the services rendered and the scope of Valley Expo & Displays' liability as herein set forth. The amounts payable to Valley Expo & Displays are unrelated to the value of the Exhibitor's property being handled by Valley Expo & Displays or its subcontractors. It is impractical and extremely difficult to fix the value of each item handled by Valley Expo & Displays or its subcontractors. It is agreed therefore that if Valley Expo & Displays or its subcontractors should be found liable for loss or damage to Exhibitor's materials, the liability shall be limited to the specific article that was physically lost or damaged. Such liability shall be limited to a sum less than or equal to the charges for services rendered as agreed upon damages, and such agreed upon damages shall be the Exhibitors exclusive remedy.

Exhibiting Company Name: \_\_\_\_\_

Booth Number(s) \_\_\_\_\_



**Register Here** for Online Ordering...  
<http://valleyexpodisplays.com/page/register>  
 EMAIL: [EVENTS@VALLEYEXPDISPLAYS.COM](mailto:EVENTS@VALLEYEXPDISPLAYS.COM)  
 FAX: 815.873.1544

**EVENT LABOR  
 VALLEY SUPERVISED  
 ORDER FORM**

**Wisconsin Police Leadership Foundation Winter Conference 2021**  
 Kalahari Resort, February 8-9, 2021

**DISCOUNT PRICE DEADLINE:**  
 1/17/2021

**Information & Requirements**

- All work is preformed under the supervision of Valley personal
- Exhibits can be set up prior to your arrival at exhibitor move in

Exhibitor must forward all necessary instruction, drawing and/or diagrams in advance with this order. Please send layout diagram to the information listed above or attach to your order online. Email [events@valleyexpodisplays.com](mailto:events@valleyexpodisplays.com) for instructions on how to attach a file on-line. A 25% Surcharge will apply to labor order if necessary documentation is not received as well as any additional labor onsite to correct resulting issues.

**Inbound Shipping & Set Up Information**

Contact Person: \_\_\_\_\_ Phone: \_\_\_\_\_  
 Email: \_\_\_\_\_  
 Freight will be shipped to:  Advance Warehouse  Direct to Show Site  
 Date Shipped: \_\_\_\_\_ Inbound Carrier: \_\_\_\_\_  
 Total # of: Crates \_\_\_\_\_ Cartons \_\_\_\_\_ Fiber Cases \_\_\_\_\_ Other \_\_\_\_\_  
 Setup Plans/Photo:  Attached to order  To be sent with Exhibit, in crate # \_\_\_\_\_  Sent to [events@valleyexpodisplays.com](mailto:events@valleyexpodisplays.com)  
 Flooring/Carpet:  With exhibit  Rented from Valley  
 Electrical Placement:  Electrical under carpet  Electrical in back of booth  Other, must provide floor plan  
 Graphic:  With exhibit  Shipped separately  
 Special Tools/Hardware/Equipment Required: \_\_\_\_\_  
 \_\_\_\_\_

**Outbound Shipping Information**

Ship to: \_\_\_\_\_  
 \_\_\_\_\_  
 \_\_\_\_\_  
 \_\_\_\_\_  
 Method of shipment\*:  Common Carrier \_\_\_\_\_  UPS  FedEx  Show Carrier  
*\*If no carrier is provided prior to the show opening, your freight will be shipped with the show carrier.*  
 If labels are provided where will they be: \_\_\_\_\_  
 Freight Charges:  Prepaid  Collect  
 Bill to: \_\_\_\_\_  
 \_\_\_\_\_

**Rate Information**

**A minimum charge** of one (1) hour per man will apply to all labor orders, with the time commencing upon assignment of labor in accordance with your order. Half (1/2) hour minimum per man is charged thereafter.  
 Labor must be cancelled in writing 24 hours in advance to avoid a one (1) hour cancellation fee per worker.  
 We will attempt whenever possible to perform the work on straight time, contingent upon the schedules of the show producer and/or convention facility.

Description	Discount	Standard
<b>Straight Time</b> - 8:00 AM and 4:30 PM on weekdays	\$ 138.65	\$ 180.25
<b>Overtime</b> - Before 8:00 AM and after 4:30 PM on weekdays and all day Saturday	\$ 207.98	\$ 270.38
<b>Double time</b> - All day Sunday and holidays	\$ 277.30	\$ 360.50

**Description of labor requested**

\_\_\_\_\_  
 \_\_\_\_\_

Estimate of Charges						
Computation of Labor Charges	# of Workers	X	# Hours	X	Labor Rate	Total Estimate
Installation					\$	\$
Dismantling					\$	\$

**Authorization to Provide Labor Services:** By completing the Event Labor Form, it is understood that Valley Expo & Displays and its subcontractors do not automatically insure materials, that insurance, if any, shall be arranged by the Exhibitor and the amounts payable to Valley Expo & Displays for labor services are based on the value of the services rendered and the scope of Valley Expo & Displays' liability as herein set forth. The amounts payable to Valley Expo & Displays are unrelated to the value of the Exhibitor's property being handled by Valley Expo & Displays or its subcontractors. It is impractical and extremely difficult to fix the value of each item handled by Valley Expo & Displays or its subcontractors. It is agreed therefore that if Valley Expo & Displays or its subcontractors should be found liable for loss or damage to Exhibitor's materials, the liability shall be limited to the specific article that was physically lost or damaged. Such liability shall be limited to a sum less than or equal to the charges for services rendered as agreed upon damages, and such agreed upon damages shall be the Exhibitors exclusive remedy.

Exhibiting Company Name: \_\_\_\_\_

Booth Number(s) \_\_\_\_\_



**Register Here** for Online Ordering...  
<http://valleyexpodisplays.com/page/register>  
 EMAIL: [EVENTS@VALLEYEXPODISPLAYS.COM](mailto:EVENTS@VALLEYEXPODISPLAYS.COM)  
 FAX: 815.873.1544

# FORKLIFT SERVICE ORDER FORM

## Wisconsin Police Leadership Foundation Winter Conference 2021

Kalahari Resort, February 8-9, 2021

DISCOUNT PRICE DEADLINE:  
1/17/2021

**PLEASE COMPLETE THIS FORM FOR ALL IN-BOOTH FORKLIFT AND LABOR NEEDED. TO DETERMINE IF YOU NEED IN-BOOTH FORKLIFT AND LABOR, PLEASE READ THIS FORM CAREFULLY.**

- In-Booth Forklift and Labor may be required to assemble displays or when uncrating, positioning, and reskidding equipment and machinery.
- A forklift is required for moving equipment and materials weighing 200 pounds or more within your booth.
- If you require a forklift, a crew will be assigned consisting of a Rigger Foreman and forklift up to 5,000lbs with an operator. Please call for quote if forklift over 5,000lbs is required.

**Forklift time required to move freight to and from the dock to your booth is included in the freight handling charges, refer to Advance or Direct order forms for further information.**

All exhibitors requesting a forklift must go to the Valley Service Desk to confirm forklift requests. All forklift crew and equipment requests should be confirmed by 2:00 pm the day prior, with the exception of the first day of move in. Requested starting times cannot be guaranteed, however, every effort is made to meet all requests. Valley reserves the right to dispatch all forklift calls based upon availability of forklift crews and in the order that the requests are confirmed. Upon completion of work, an exhibitor representative must return to the Valley Service Desk to sign the completed work ticket and confirm accuracy of the work order. No adjustments will be made after the event. Forklift orders cancelled without a 24 hour notice will be charged a one (1) hour cancellation fee per worker and equipment ordered. If the forklift is not used at the time confirmed, there will be a one (1) hour no-show fee charged per worker and equipment ordered.

The minimum charge for forklift crew is one (1) hour per worker and forklift. Forklift rental thereafter is charged in half (1/2) hour increments. All rates are subject to change if necessitated by increased labor and material costs.

**Important Information & Rates**

Description	Discount Rate (per hour)	Standard Rate (per hour)
<b>Straight Time</b> - 8:00 AM and 4:30 PM on weekdays	\$ 290.35	\$ 377.50
<b>Overtime</b> - Before 8:00 AM and after 4:30 PM on weekdays and all day Saturday	\$ 435.53	\$ 566.25
<b>Double time</b> - All day Sunday and holidays	\$ 580.70	\$ 755.00

When scheduling dismantle, be sure to allow sufficient time for empty containers to be returned to your booth

**Hours of Operation**

Move In Dates & Times

2/7/2021; 12:00pm-6:00pm  
2/8/2021; 7:00am-9:00am

Move Out Dates & Times

2/9/2021; 3:00pm-7:00pm

**Required Information**

Does the weight exceed 5,000lbs  No  Yes, \_\_\_\_\_ total weight

Is there any special handling equipment required to lift materials, i.e. extended forklift blades, special slings, etc.?  No  Yes  
 please describe needs: \_\_\_\_\_

INSTALLATION						
Schedule Date(s)	Schedule Start Time	Schedule End Time	Total # of Hours	Total # of Forklifts	Labor Rate	Total

Please Indicate Service to be provided:  
 Uncrating  Leveling  Unskidding  Positioning  Exhibit Construction (describe work below)  Other

Other: Please describe work

DISMANTLE						
Schedule Date(s)	Schedule Start Time	Schedule End Time	Total # of Hours	Total # of Forklifts	Labor Rate	Total

Please Indicate Service to be provided:  
 Recrating  Dismantling  Recrating  Other

Other: Please describe work



**Register Here** for Online Ordering...  
<http://valleyexpodisplays.com/page/register>  
 EMAIL: EVENTS@VALLEYEXPODISPLAYS.COM  
 FAX: 815.873.1544

**BOOTH & EXHIBIT  
 PORTER SERVICE  
 ORDER FORM**

**Wisconsin Police Leadership Foundation Winter Conference 2021**

Kalahari Resort, February 8-9, 2021

DISCOUNT PRICE DEADLINE:  
 1/17/2021

Orders must be placed by **1/17/2021** to receive discount pricing. Orders received after deadline date will be placed at floor pricing.

Submit this form if you want to order Valley Expo & Displays cleaning service for your booth in order to maintain booth cleanliness post set-up or throughout the entire event. Prices are based on total square footage of booth regardless of area to be cleaned.

**Standard Booth Size ( 8'x10' ) = Square Footage ( 80 square feet per booth )**

**Carpet Vacuuming:** Booth carpeting is clean upon installation; however, vacuuming services are available. Charges are based on booth square footage. Display installation can result in soiled carpet; therefore, we recommend ordering vacuuming at least once prior to show opening.

**Carpet Vacuuming**

	Sq. Ft.	X	Discount	Standard	=	Total
Once Prior to Show Opening	_____		\$ 0.65	\$ 0.85		_____
2 Days - Prior to Show Opening Each Day	_____		\$ 0.70	\$ 1.50		_____
3 Days - Prior to Show Opening Each Day	_____		\$ 1.80	\$ 2.35		_____
4 Days - Prior to Show Opening Each Day	_____		\$ 2.30	\$ 3.00		_____

**Porter Service:** Includes wipedown & dusting of all display surfaces and furnishings, and emptying of wastebaskets nightly.

**Porter Service**

	Sq. Ft.	X	Discount	Standard	=	Total
Once Prior to Show Opening	_____		\$ 0.70	\$ 0.95		_____
2 Days - Prior to Show Opening Each Day	_____		\$ 1.25	\$ 1.65		_____
3 Days - Prior to Show Opening Each Day	_____		\$ 1.95	\$ 2.55		_____
4 Days - Prior to Show Opening Each Day	_____		\$ 2.50	\$ 3.25		_____

Exhibiting Company Name: \_\_\_\_\_

Booth Number(s) \_\_\_\_\_

<b>Subtotal</b>	\$	_____
<b>6.75% Sales Tax</b>	\$	_____
<b>Total</b>	\$	_____





**Register Here** for Online Ordering...  
<http://valleyexpodisplays.com/page/register>  
 EMAIL: [EVENTS@VALLEYEXPODISPLAYS.COM](mailto:EVENTS@VALLEYEXPODISPLAYS.COM)  
 FAX: 815.873.1544

**SIGN &  
 BANNER  
 ORDER FORM**

**Wisconsin Police Leadership Foundation Winter Conference 2021**  
 Kalahari Resort, February 8-9, 2021

ORDERING DEADLINE:  
 1/17/2021

This form can be used to order custom show cards and banners for your exhibit booth. **Custom signs and banners can be ordered in advance only.** We must receive your order with payment by **1/17/2021** to guarantee delivery.

Labor to install signs or banners is not included. Please refer to the Event Labor Order Form for assistance in installing your signs if it will be needed. All signs are printed on white background. 10 word limit per sign. Additional words and logos are extra.

Valley has added the Vanguard Digital Printing Systems VR5D flatbed UV printer. It combines revolutionary technology, industry leading quality and outstanding speeds to satisfy the demands of the industry schedule. With the VR5D it gives the ability to print on a variety of substrates including foam, pvc, vinyl, acrylic and more! Our sign shop can produce any type of sign or banner you need, including multiple colors, photographic reproductions, etc. If an option or feature you want is not listed on this form, please call us for a special quote.

**Upload your artwork to:** <http://ftp.hostedftp.com/~valleyexpo> **Or email to** [events@valleyexpodisplays.com](mailto:events@valleyexpodisplays.com) **Please see the following page for artwork requirements on "Supplied Digital Arts Standards" form. Contact name, E-mail address and phone number are requested in case we have questions.**

**Contact for sign questions:** \_\_\_\_\_

**Email:** \_\_\_\_\_

**Phone:** \_\_\_\_\_

	Description	Quantity	Price	Total
Foamcore Signs White Background	11" x 14"	_____	\$ 72.35	_____
	14" x 22"	_____	\$ 105.10	_____
	22" x 28"	_____	\$ 128.40	_____
	28" x 44"	_____	\$ 174.65	_____
Vinyl Banners White Background Only	2' X 4'	_____	\$ 176.35	_____
	2' X 6'	_____	\$ 212.65	_____
	2' X 8'	_____	\$ 310.65	_____
	Grommets for hanging are included			
Miscellaneous	Easel Back	_____	\$ 13.90	_____
	Sign Grommets	_____	\$ 5.40	_____
	Color Background	_____	\$ Add 25%	_____

Sign copy to be arranged:  Horizontally  Vertically

<b>Subtotal</b>	\$	_____
<b>6.75% Sales Tax</b>	\$	_____
<b>Total</b>	\$	_____



Exhibiting Company Name: \_\_\_\_\_

Booth Number(s) \_\_\_\_\_



**VALLEY**

Register Here for Online Ordering...  
<http://valleyexpodisplays.com/page/register>  
 EMAIL: [EVENTS@VALLEYEXPDISPLAYS.COM](mailto:EVENTS@VALLEYEXPDISPLAYS.COM)  
 FAX: 815.873.1544

**SUPPLIED DIGITAL  
ART STANDARDS**

Wisconsin Police Leadership Foundation Winter Conference 2021

Kalahari Resort, February 8-9, 2021

DISCOUNT PRICE DEADLINE:

1/17/2021

## Supplied Digital Art Standards

In an effort to provide you with the best graphics for your display, Valley requests that you review these file and media requirements when you supply digital art. Supplying the proper files insures that your output will look the way you expect, and keep additional charges to a minimum. If you have questions about file formats, resolution, or other graphics concerns, please call us at **815-873-1500** or e-mail [events@valleyexpodisplays.com](mailto:events@valleyexpodisplays.com)

### Raster (Pixel-based) Art -

Raster art is the way most continuous tone images are produced. Scanned images, Photoshop files, tif, jpg, & bmp are examples of raster or pixel-based art. Resolution for these files should be at least 300dpi *at output size*. For example, a file for 16 x 20 inch output should be 4800 pixels by 6000 pixels. Both cmyk and rgb are acceptable but **cmyk is preferred**. **Its helpful if all your files are consistently one or the other.**

#### Use for:

**Photographic or continuous tone images.**

### Vector Art -

Vector art is 'resolution independent', meaning it can be scaled to any size with no loss of quality. Illustrations created in Adobe Illustrator or Freehand are vector art. EPS files are the most common format for vector art.

**NOTE:** A Raster image imported or placed, and then saved in these programs is not changed into vector art...*it is still a raster image* and may not be suitable for some output options.

Logos & illustrations produced as cut vinyl **MUST** be vector art. If you cannot supply vector art, you may be charged for the time required to convert/recreate your art in the proper format.

#### Use for:

**Cut vinyl, large format text, logos, graphic elements.**

**Art Size:** Art files should be submitted with at least 0.5" bleed. (ex. 22" x 28" sign would be 22.5" x 28.5")

**Raster Art** can be supplied as Photoshop, jpg, tif, eps, bmp or other standard raster formats.

**Vector Art** should be **Adobe Illustrator (.ai), InDesign (.indd) or .eps (from Illustrator or InDesign)** files with text converted to paths. Include all linked files. If text is not converted to paths, all fonts must be included. When sending vector art use the package option in Illustrator or InDesign to properly export all necessary files.

**QuarkExpress** users, supply eps files with fonts embedded. Native Quark files are no longer supported.

**Media:** CD or DVD. For FTP access contact your Valley representative.

**Please include a color hardcopy or pdf. Critical PMS colors should be indicated on the hardcopy.**

## Still have questions?

Call 815-873-1500

or

E-mail: [events@valleyexpodisplays.com](mailto:events@valleyexpodisplays.com)





Valley Expo & Displays  
Specialty Furnishings



To view complete brochure and order forms please click on the link below:

Click on Link: [Valley Specialty Furnishings Brochure & Order Forms](#)

# COVID PREVENTION SERVICE KIT



## TABLETOP SNEEZE GUARDS



Help maintain social distance and physical separation while protecting from splashes and sprays with clear plastic barriers.

- 1/8" Thick and 44" Wide
- Choice of 22", 31" or 36" Heights
- Bank Slots offered for all sizes
- White Sintra Feet
- Made in the U.S.A.

44"w x 22"h  
**\$127.50 each**

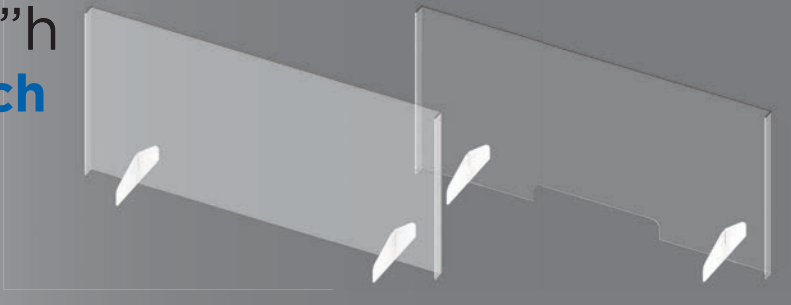

44"w x 31"h  
**\$172.50 each**

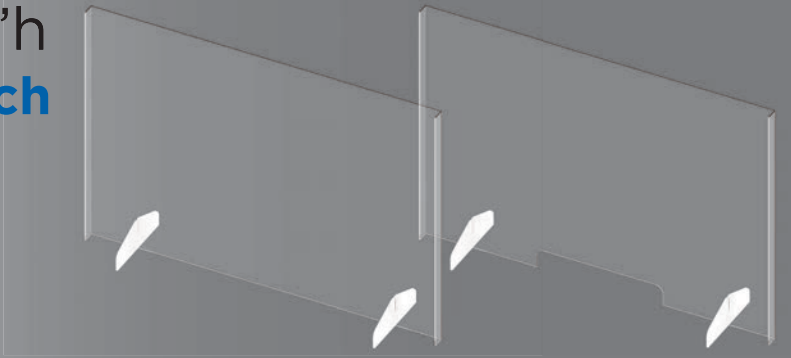

44"w x 36"h  
**\$202.50 each**

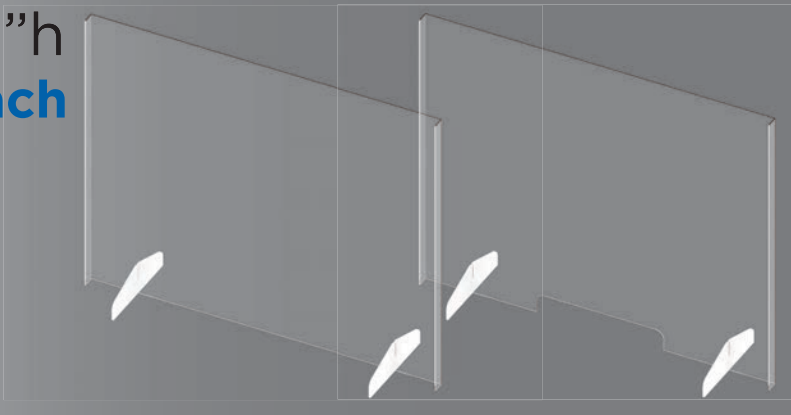

# COVID PREVENTION SERVICE KIT



## FACE MASKS



### Disposable Face Masks

1. Made of environmental friendly material, moisture-proof, non-toxic, non-irritating, soft and comfortable
2. Special 3 layer non-woven design provides protections against dust, automobile exhaust, pollen, etc.
3. Elastic ear loop is easy to wear and no pressure to the ears
4. Up to 95% filtration efficiency

Pricing: \$2.60 per mask (\$260) 100 mask minimum



### Branded Face Masks

Full color dye-sublimated civilian bandana style face mask. Single ply polyester fabric.

Individually packaged. 21.5" x 21.5".

Quantity 100 - \$5.50 each (\$550 total)  
Quantity 500 - \$4.50 each (\$2,250 total)  
Quantity 1000 - \$3.75 each (\$3,750 total)



### Branded Face Masks

1 Location – Multi – color transfer, Polyester Outside, Poly-cotton Blend Liner, “Loop Over” ear holders

Quantity 100 - \$10.00 each (\$1,000 total)  
Quantity 500 - \$8.00 each (\$4,000 total)  
Quantity 1000 - \$7.25 each (\$7,250 total)



\*Must be ordered minimum 4 weeks before event move in for all face mask orders above

# COVID PREVENTION SERVICE KIT



## OTHER PROTECTIVE MATERIALS

### 2 oz Hand Sanitizer with Branding

Hand Sanitizer with your branding printing on the bottle. Pricing below for branded options.

Quantity 200 - \$3.00 each (\$600 total)

Quantity 600 - \$2.75 each (\$1,650 total)

Quantity 2000 - \$2.25 each (\$4,500 total)

\*Must be ordered minimum 4 weeks before event move in



### Clear Vinyl Sidewall Divider

This clear wall divider can be used for your sidewall to protect from a neighboring booth.

This wall is 8' tall and 10' wide and it is flame resistant.

Price per wall is \$225.00

\*Must be ordered minimum 4 weeks before event move in

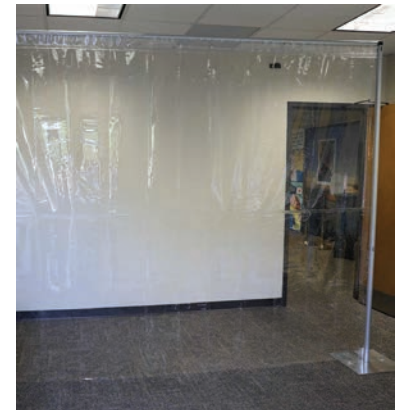

### 8' High Drape Sidewall Divider

This drape wall divider can be used for your sidewall to protect from a neighboring booth.

This wall is 8' tall and 10' wide and it is flame resistant.

Price per wall is \$175.00

\*Must be ordered minimum 4 weeks before event move in



# COVID PREVENTION SERVICE KIT



## BOOTH SANITIZATION



We will come sanitize your booth with our industry recommended sanitizing solution.

**Pricing:** Under 100 Sq Ft - \$125  
 101 Sq Ft - 399 Sq Ft - \$175  
 400 Sq Ft - \$225  
 Over 400 Sq ft call for quote

Pricing above is for one application.



## BANNERSTAND/HAND SANITIZER

- 1000ml battery operated sanitizer dispenser with lock
- Accessory channel holds upright and sanitizer dispenser
- Variable height graphic = 60" - 83"
- Hybrid bungee/ telescoping pole with toolless quick rail
- Adjustable feet on base
- Anodized silver base only
- Quick slide graphic to leader attachment
- Graphic tensioner
- Supplied with carry bag with strap
- You will have to supply your own sanitizer

Price per unit is \$475



# COVID PREVENTION SERVICE KIT



## SAFETY WALL DIVIDERS



### 36" Curved Safety Dividers

- Dims: 36" W x 90" H x 0.75" D
- Engineered Aluminum Extrusion
- Satin Anodized Finish
- Curved Design
- Clear Acrylic Infill -- Standard
- Base Plate or Castors

Price per unit is \$850



### 48" Curved Safety Dividers

- Dims: 48" W x 90" H x 0.75" D
- Engineered Aluminum Extrusion
- Satin Anodized Finish
- Curved Design
- Clear Acrylic Infill -- Standard
- Base Plate or Castors

Price per unit is \$950



# COVID PREVENTION SERVICE KIT



## 10'X10' HARDWALL W/ PLEXI SIDEWALLS



Aluminum extrusion frame with graphic infill panels on the back wall (3 panels) and plexiglass side wall panels (6 total). The dimensions are 10' wide x 8' high. Includes standard 4', 6' or 8' skirted table with two chairs.

Rentals include: standard carpeting, visqueen, padding, graphics, material handling, installation and dismantle of exhibit only.

NOT Included: Graphic taxes and outbound shipping of your purchased graphic from the event.

Price per unit is \$3,500.00

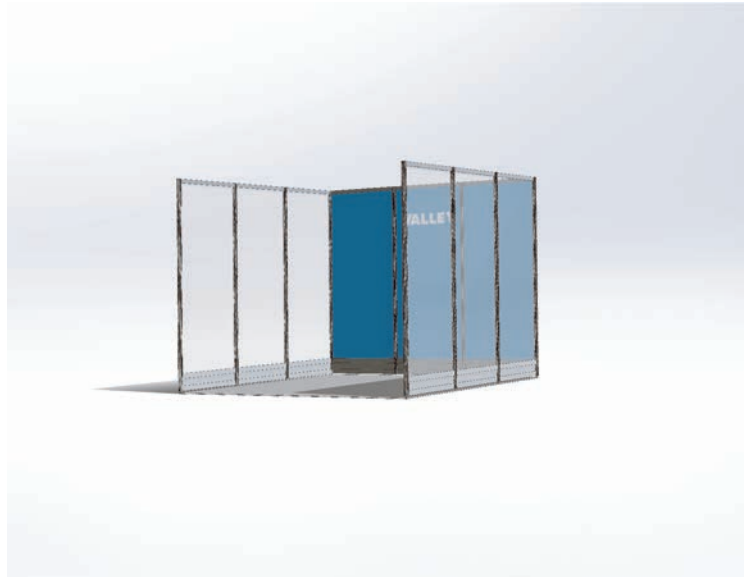
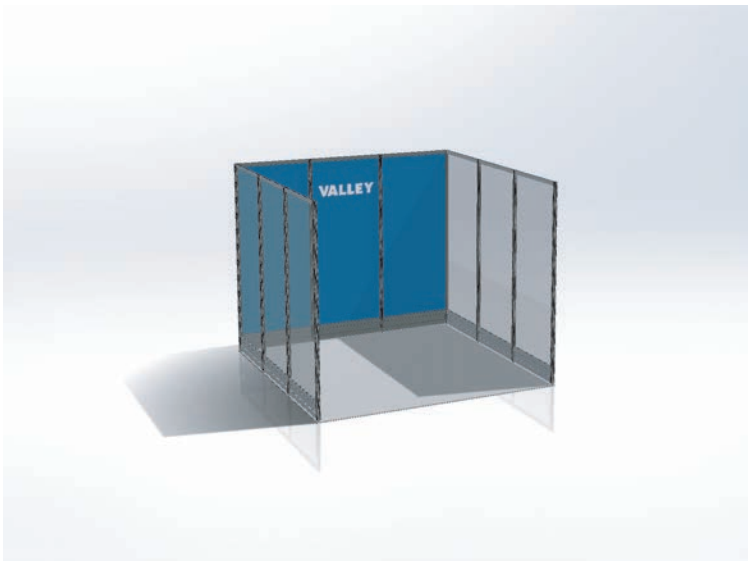



# COVID PREVENTION SERVICE KIT



## 10'X10' HARDWALL W/ PLEXI SIDEWALLS & FRONTWALL

Aluminum extrusion frame with graphic infill panels on the back wall (3 panels) and plexiglass side wall panels (6 total). Also includes (2) plexiglass front wall that can be adjusted to left, right or center of booth. The dimensions are 10' wide x 8' high. Includes standard 4', 6' or 8' skirted table with two chairs.

Rentals include: standard carpeting, visqueen, padding, graphics, material handling, installation and dismantle of exhibit only.

NOT Included: Graphic taxes and outbound shipping of your purchased graphic from the event.

Price per unit is \$4,250.00

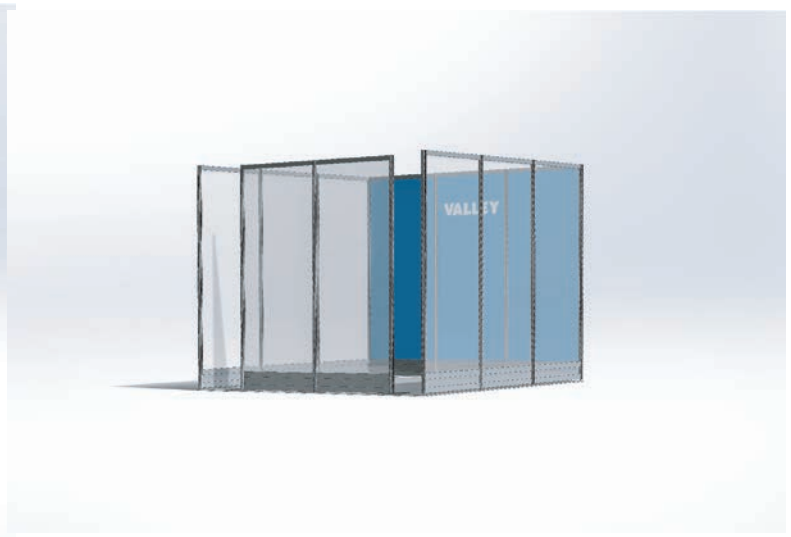

# COVID PREVENTION SERVICE KIT



## 10'X10' BEMATRIX HARDWALL W/ PLEXI SIDEWALL



Freestanding hardwall constructed of aluminum extrusion with plexiglass sidewall panels. Graphics are produced on fabric with seg to apply to frame. Dimensions are 117" w x 96" h and 4" deep at backwall and on the side walls. Includes standard 4', 6' or 8' skirted table with two chairs. In total comes with (3) graphic panels and (6) plexiglass panels.

Rentals include: standard carpeting, visqueen, padding, graphics, material handling, installation and dismantle of exhibit only.

NOT Included: Graphic taxes and outbound shipping of your purchased graphic from the event.

Price per unit is \$5,000.00

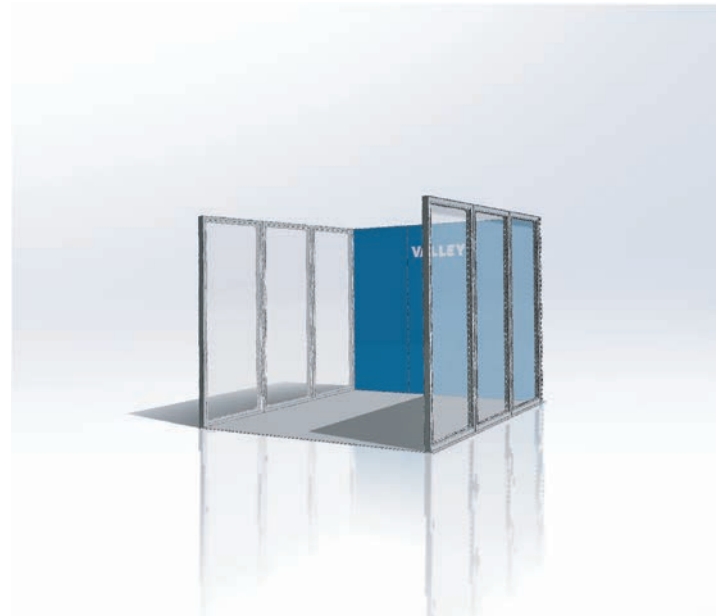

# COVID PREVENTION SERVICE KIT



## 10'X10' BEMATRIX HARDWALL W/ PLEXI SIDEWALL & FRONTWALL



Freestanding hardwall constructed of aluminum extrusion with plexiglass sidewall panels. Also includes (2) plexiglass front wall that can be adjusted to left, right or center of booth. Graphics are produced on fabric with seg to apply to frame. Dimensions are 117" w x 96" h and 4" deep at backwall and on the side walls. Includes standard 4', 6' or 8' skirted table with two chairs. In total comes with (3) graphic panels and (8) plexiglass panels.

Rentals include: standard carpeting, visqueen, padding, graphics, material handling, installation and dismantle of exhibit only.

NOT Included: Graphic taxes and outbound shipping of your purchased graphic from the event.

Price per unit is \$5,750.00



# (Kalahari Fax 608.254.8609) Service Order Form

## Service Order Form For Trade Show Exhibitors

Name of Show / Event: \_\_\_\_\_ Date of Show / Event: \_\_\_\_\_  
 Company / Booth Name: \_\_\_\_\_ Booth Number: \_\_\_\_\_  
 Contact Name: \_\_\_\_\_ Phone: \_\_\_\_\_ Fax: \_\_\_\_\_  
 Email Address \_\_\_\_\_  
 Address: \_\_\_\_\_  
 City: \_\_\_\_\_ State: \_\_\_\_\_ Zip: \_\_\_\_\_

### Telecommunications / Other Utilities

Qty	Description	Charge	# of days	Total	Qty	Description	Charge	# of days	Total
___	Analog Phone Line	\$30 / day	_____	_____	___	Water Hook UP (available in certain areas)	\$50 / Flat	_____	_____
___	VGA Projector	\$300 / day	_____	_____	___	32" Monitor	\$75 / day	_____	_____
___	Lexon Ice	\$25	_____	_____	___	60" Monitor <small>(Limited Availability)</small>	\$200 / day	_____	_____
					___	Static IP Address	\$200 Flat	_____	_____
					___	6' x 8' Screen	\$40 / day	_____	_____
					___	High Speed Internet	\$75 / day	_____	_____

TOTAL: \_\_\_\_\_  
 21% surcharge (if applicable): \_\_\_\_\_  
 Sales Tax: 6.75% of Sub-Total: \_\_\_\_\_  
 TOTAL AMOUNT DUE: \_\_\_\_\_

### Rules and Regulations

1. Some services are on a first come / first served basis.
2. Orders received less than 10 (ten) days prior to show will be charged a 21% surcharge for the total order.
3. Orders received without payment will be charged a 21% surcharge for the total order.
4. Canceled orders, prior to show, will receive a 50% refund.
5. Kalahari Resort is not responsible for any power surges or other power fluctuations.
6. The use of triple or quad attachment plugs is strictly prohibited.
7. Fuel powered equipment or vehicles, open flames, and exhibits over 2000 pounds must receive prior approval in writing from the resort.
8. Any damage to the resort will be the sole responsibility of the exhibitor.
9. Exhibit space is carpeted. Exhibitor is responsible for repair / replacement charges to damaged carpet.
10. Specific plug adapters to match Kalahari's available plugs are exhibitors responsibility.

I have read, understand and agree to all the Rules and Regulations as stated above.

\* A Kalahari representative will call you for payment information once the service order has been received.